

(19)



(11)

**EP 1 883 213 A1**

(12)

**EUROPEAN PATENT APPLICATION**

(43) Date of publication:  
**30.01.2008 Bulletin 2008/05**

(51) Int Cl.:  
**H04M 1/60 (2006.01) H04M 1/24 (2006.01)**

(21) Application number: **06015385.5**

(22) Date of filing: **24.07.2006**

(84) Designated Contracting States:  
**AT BE BG CH CY CZ DE DK EE ES FI FR GB GR HU IE IS IT LI LT LU LV MC NL PL PT RO SE SI SK TR**  
Designated Extension States:  
**AL BA HR MK YU**

- **Schmidt, Gerhard**  
89081 Ulm (DE)
- **Schnug, Walter**  
87700 Memmingen (DE)
- **Tropp, Michael**  
89160 Dornstadt (DE)

(71) Applicant: **Harman Becker Automotive Systems GmbH**  
76307 Karlsbad (DE)

(74) Representative: **Bertsch, Florian Oliver et al**  
**Kraus & Weisert,**  
Thomas-Wimmer-Ring 15  
80539 München (DE)

(72) Inventors:  
• **Kolano, Guido**  
73084 Salach (DE)

**(54) System and method for calibrating a hands-free system**

(57) The present invention relates to a method for calibrating a hands-free system, the hands-free system comprising a hands-free unit and a mobile phone, the method comprising the following steps:  
- setting up a connection between the hands-free system and a distant terminal via a mobile telephony network of the mobile phone,  
- transmitting a predetermined test signal from one of the hands-free system and the distant terminal to the other

of the hands-free system and the distant terminal, the predetermined test signal being provided in both the hands-free system and the distant terminal as reference test signal,  
- comparing the received test signal to the reference test signal stored in the other of the hands-free system and the distant terminal, and  
- determining the calibration parameters of the hands-free system in accordance with the comparison.

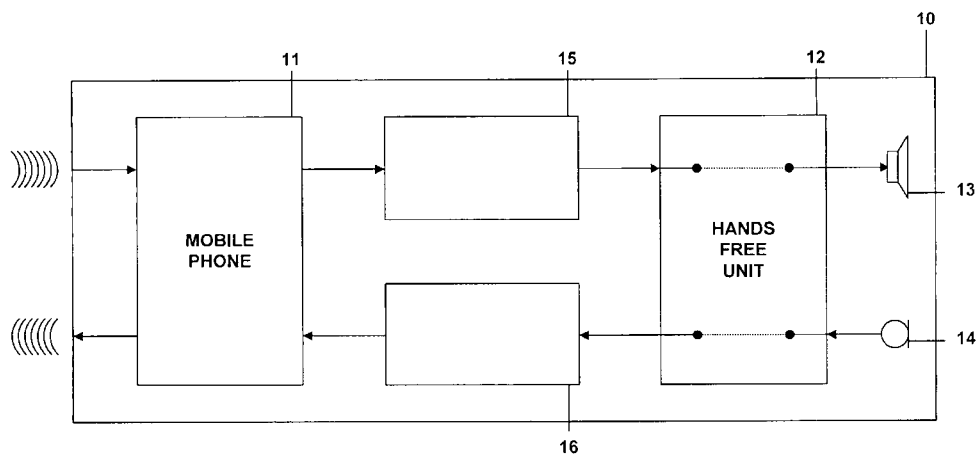

**FIG. 1**

**EP 1 883 213 A1**

## Description

### Field of the Invention

**[0001]** This invention relates to a method and a system for calibrating a hands-free system. The invention relates especially to a hands-free system used in a vehicle.

### Related Art

**[0002]** In vehicles hands-free systems are used for outputting audio signals of a remote subscriber using the loudspeakers which are normally provided in a vehicle. For picking up the signals of the passengers in the vehicle several microphones are installed in different locations in the vehicle which can be used instead of the microphones provided in the mobile phone in connection with the hands-free system. Additionally, signal processing can be used which is adapted to the vehicle environment. By way of example noise reduction systems are used which are optimized to the different types of vehicles and which reduce the noise component in the signal detected by the microphone of the hands-free system.

**[0003]** For improving the speech quality in hands-free systems an adaption of the hands-free system to the mobile phone which is used in connection with the hands-free system is necessary. By way of example a signal level coming from a remote user should always result in a same signal level which is output via the loudspeaker. The signal level should not depend on the mobile phone used in connection with the hands-free system. Mobile phones normally have different signal output levels so that an equalization of the signal level depends on the used mobile phone.

**[0004]** In the art it is known to provide equalization parameters for the most commonly used mobile phones in order to adapt the hands-free system to the used mobile phones. These parameters can be stored in a storage unit of the hands-free system. When a mobile phone is connected to a hands-free system either wireless via Bluetooth or when the mobile phone is put into the cradle, the mobile phone is identified as far as the type of mobile phone is concerned. When it is known which type of mobile phone is used the corresponding calibration or equalization parameters can be loaded and used in a calibration unit in order to adapt the hands-free system to the mobile phone (e.g. by adapting the frequency response or by adapting the signal level).

**[0005]** This kind of calibration, however, has several drawbacks. When the calibration parameters are only determined for a specific type of mobile phone, an individual calibration to the mobile phone presently used is not possible. There exist significant differences between different mobile phones of a certain type. Such differences may be due to the amplifiers used in the mobile phones. These amplifiers often have a varying output signal level of  $\pm 3$  to 6 dB. An adaptation to the type of mobile phone used does not result in an optimum speech

signal quality, as the processing parameters vary within one type of mobile phone.

**[0006]** Furthermore, it is possible that the calibrating parameters of a mobile phone change. By way of example when a new software release is used in the mobile phone the signal processing changes. In the event that a predetermined set of calibration parameters is used these calibration parameters will be continuously used after the software update even if the characteristics of the mobile phone have changed. Even if new calibrated parameters are transmitted together with the software update, the problem may exist that some of these mobile phones use an older software version than other mobile phones of the same type. Normally, a differentiation between the different software types is not possible, as the actual version of the used software is normally not transmitted to a hands-free system during identification of the mobile phone.

**[0007]** A further disadvantage of known systems lies in the fact that calibration parameters can only be determined for mobile phones already existing on the market. When a new mobile phone is developed, the hands-free system may not have the corresponding calibration parameters, as the life cycle of a mobile phone is normally much shorter than the life cycle of a hands-free system used in a vehicle.

**[0008]** Summarizing in prior art hands-free systems several drawbacks exist resulting in a non-optimal speech quality of the hands-free system.

### Summary

**[0009]** Accordingly a need exists to provide a hands-free system in which the speech quality can be further improved and in which each individual mobile phone can be adjusted to the hands-free system.

**[0010]** This need is met by the features of the independent claims. In the dependent claims preferred embodiments of the invention are described.

**[0011]** According to a first aspect of the invention a method for calibrating a hands-free system is provided, the hands-free system comprising a hands-free unit and a mobile phone, the method comprising the steps of setting up a connection between a hands-free system and a distant terminal via the mobile telephony network of the mobile phone. When a connection between the hands-free system and the distant terminal has been built up, a predetermined test signal is transmitted from one of the hands-free system and the distant terminal to the other of the hands-free system and the distant terminal. This test signal is also provided in both the hands-free system and the distant terminal as a reference test signal. Due to the fact that the reference test signal is also provided in the receiving unit of both terminals the received test signal can be compared to the reference test signal stored in the other of the hands-free system and the distant terminal where the test signal was received. Furthermore, the calibration parameters of the hands-free sys-

tem are then determined in accordance with the comparison. This method has the advantage that each individual mobile phone can be adapted to the hands-free system with which it is used. Accordingly, it is possible to calibrate a hands-free system during normal operation by the customer and not only before delivering the system as in the prior art. For this reason also new mobile phones which were not on the market at the time of delivering the hands-free system can be calibrated and equalized automatically. It has been shown that calibrating the mobile phones individually improves the overall speech quality remarkably.

**[0012]** It is possible to calibrate the receiving path as well as the transmitting path of the combined system comprising the hands-free unit and the mobile phone. When the receiving path should be calibrated, the predetermined test signal is transmitted from the distant terminal to the hands-free system. The transmitted test signal is then received by the hands-free system and is compared to the reference test signal already provided in the hands-free system. By comparing the received signal to the reference test signal the influence of the receiving path of the hands-free system can be determined and the calibration parameters of the receiving path can now be adapted in accordance with the comparison. By comparing the reference test signal to the received test signal the influence of the receiving path of the system can be determined. The calibration parameters can now be controlled in such a way that this influence due to the receiving path can be removed by setting the calibration parameters in such a way that the received test signal substantially corresponds to the stored reference signal which did not undergo the transmission.

**[0013]** According to another aspect of the invention, each time when the mobile phone is used together with a hands-free unit the mobile phone is identified. When it is known which mobile phone is used it can be verified whether this mobile phone has already been used together with the hands-free unit before and whether a calibration has been carried out. If no calibration has been carried out for the presently used mobile phone, the calibration steps can be initiated.

**[0014]** The user of the mobile phone needs not to be informed of the calibration. To this end the received test signal transmitted from the distant terminal may not be output via the loudspeaker of the hands-free unit. Furthermore, the audio signal picked up by the microphone will not be transmitted to the distant terminal, as this distant terminal may only be used for calibrating the system.

**[0015]** It is possible to choose a test signal from a large variety of test signals. Preferably, a broadband time variant signal is used as test signal. In the present context a broadband test signal means that the bandwidth of the test signal substantially corresponds to the bandwidth of the audio signal transmitted by the mobile phone. Normally, the bandwidth transmitted in such communication systems is between 50 and 4,000 Hz. However, there exist also transmission systems transmitting frequency

spectra up to 7,000 Hz. For measurements purposes in these telecommunication systems an artificial voice signal is recommended by the ITU (International Telecommunication Union). It is mathematically defined such that it models human speech. The long and short term spectra, the probability density function of speech signals, the voiced or unvoiced structure and the syllabic envelope for male and female speech are emulated.

**[0016]** Furthermore, it is also possible to use a composite source signal that comprises e.g. the following three sections: a 50 ms long voice signal taken from artificial voice intended to activate speech detectors in the system, a pseudo noise signal of about 200 ms duration during which measurements can be taken, and a pause that is long enough to set the system back into its quiescence state. The composite source signal can be repeated several times with alternative polarities. However, the invention is not limited to the above-mentioned test signals. The test signal used will also depend on the storage capacities of the hands-free system. If the storage capacity is limited, it is also possible to use shift registers for generating a test signal. In this case the register is filled with data. By xor-combinations of the different bit entries test signals can be generated. The time dependence of these test signals can be achieved by using a time variant damping element connected after the shift register.

**[0017]** There exist different ways of generating the test signals. According to one aspect of the invention the test signal and the reference test signal should be generated the same way in a distant terminal and the hands-free system. When these two signals are generated the same way it can be assured that by comparing the transmitted test signal to the reference test signal only the influence of the transmission is present in the different signals.

**[0018]** Furthermore, it is possible to calculate the propagation time difference or delay time between the transmitted test signal and the reference test signal provided in the other of the distant terminal and the hands-free system before the calibration parameters are determined. By way of example the propagation time difference can be determined with the help of a correlation function. When the propagation time is known, the influence of the signal transmission can be taken into account when the received test signal is compared to the reference test signal.

**[0019]** One possibility to further analyze the hands-free system and to calculate the calibration parameters is to determine a time-averaged signal level of the received signal and to compare this averaged signal level to the time-averaged signal level of the reference test signal. The difference of the levels can then be removed by adapting the calibration parameters in such a way that the signal level of the received test signal substantially corresponds to the signal level of the reference test signal. By adapting the signal level variations the signal amplification between different mobile phones can be removed.

**[0020]** In addition to the signal level correction it is also possible to determine the power density spectrum of the received test signal and to compare the power density spectrum of the stored signal to the power density spectrum of the received test signal, the equalizing parameters of the hands-free system being determined in such a way that the power density spectrum of the received test signal substantially corresponds to the power density spectrum of the reference test signal. By way of example this correction of the frequency response is possible by determining the discrete Fourier transformation. Furthermore, the spectrum can also be determined using a LPC (Linear Predictive Coding) analysis. In the last case the equalization can be achieved using a FIR or IIR filter. In both possibilities to calculate the spectrum the maximum attenuation and the maximum amplification should be limited. If by way of example a large attenuation of the transmitted signal at low frequencies should be removed, the noise of the system would be amplified without the use of a limitation of the attenuation. In order to avoid this noise amplification, maximum signal amplification and attenuation has to be determined as an upper and lower limit.

**[0021]** Another possibility for calibrating the system can be to determine whether in the receiving path of the mobile phone an automatic feedback control of the signal amplification is carried out. This can be achieved by using a test signal with varying signal level. If this automatic feedback control for the amplification is carried out, the amplification of the received signal in the hands-free unit should be adjusted to the signal amplification in the mobile phone.

**[0022]** Furthermore, it is possible to determine whether a noise reduction is carried out in the receiving path of the mobile phone by comparing the signal-to-noise-ratio of the received signal to the signal-to-noise-ratio of the provided reference signal. If a noise reduction is carried out in the mobile phone, the noise reduction in the hands-free system should be deactivated or adapted in accordance with the noise reduction in the mobile phone. By way of example when the overall system should have a maximum attenuation of 12 dB and if a noise reduction was carried out in the mobile phone by 8 dB, the parameters of noise reduction in the hands-free unit have to be adapted in such a way that the maximum reduction in the hands-free unit is 4 dB. In addition to the noise reduction it can be determined whether a signal level limitation is activated in the mobile phone. If this is the case, the amount of signal level limitation is determined and the signal level limitation in the hands-free unit is adapted in accordance with the signal level limitation in the mobile phone. In one embodiment of the invention the activation of a signal level limitation can be detected by using a test signal having a large signal amplitude reaching the maximum possible amplitude.

**[0023]** Furthermore, according to another embodiment of the invention the frequency response of the mobile phone can be determined by comparing the spectrum

of the received test signal to the spectrum of the reference test signal, the determined frequency response of the mobile phone being used for extending the bandwidth of the received audio signal of the mobile phone in wireless communication systems such as mobile telephone networks. The frequency components below a certain frequency such as 200 Hz or above a maximum frequency such as around 3,400 Hz are not transmitted by the transmission system. In order to improve the speech quality, these frequency components can be calculated and added to the received signal. For the calculation or estimation of the missing frequency components it is advantageous to correctly determine the frequency response of the mobile phone. In this case the bandwidth extension can be improved, the improved bandwidth extension resulting in a better signal quality of the speech signal.

**[0024]** When a connection between the hands-free system and the distant terminal is set up, it is also possible that the hands-free system first of all transmits the identification code to the distant terminal identifying the used hands-free unit and the mobile phone. This transmission of a signal to the distant terminal can also initiate the transmission of the test signal from the distant terminal to the hands-free system when the receiving path of the hands-free system comprising the mobile phone should be calibrated.

**[0025]** According to another embodiment of the invention it is also possible to calibrate the transmission path of the hands-free system. In this case the predetermined test signal is transmitted from the hands-free system to the distant terminal where the received signal is compared to the reference test signal stored in the distant terminal. By comparing these two signals the calibration parameters of the transmitter of the hands-free system can be calculated at the distant terminal and can then be transmitted to the hands-free system where they can be used for calibrating the transmission path of the hands-free system. As it is the case for the calibration of the receiving path of the hands-free system, the loudspeaker of the hands-free system may not be activated when the different signals are transmitted to the distant terminal. The user of the hands-free system needs not to be bothered by the outputting of the different test signals via the loudspeaker.

**[0026]** The invention further relates to a system for calibrating a hands-free system, the hands-free system comprising a hands-free unit and a mobile phone. The calibration system comprises the hands-free system, the latter additionally comprising a loudspeaker for outputting a signal received by the mobile phone, and a microphone picking up a speech signal of a user of the hands-free system. Additionally, a first storage unit may be provided in the hands-free system storing the reference test signal. The calibration system further comprises a distant terminal transmitting a test signal to the hands-free system and/or receiving a test signal from the hands-free system, the distant terminal comprising a second storage unit also storing the reference test signal. As described

above, the test signal is transmitted from one of the hands-free system and the distant terminal to the other, the system further comprising a calibration unit adapting the hands-free system to the used mobile phone, the calibration unit comparing the received test signal to the stored reference test signal and determines the calibration parameters in accordance with said comparison.

**[0027]** Hands-free systems are often used with different mobile phones. Accordingly, the calibration system may further comprise means for identifying the mobile phone used in connection with the hands-free unit, the calibration unit starting to adapt the mobile phone to the hands-free unit when it is detected that a mobile phone is used in connection with the hands-free unit for which no calibration has been carried out. When it is determined that for the used mobile phone a calibration has already been carried out, it is not necessary to re-calibrate the system if not wanted by the user.

**[0028]** It is possible that the calibration is initiated by the user of the mobile phone. When the software of the mobile phone has been updated, the processing of the audio signal may have changed. In this case it might be advantageous to recalibrate the hands-free system even if a calibration has been carried out for the same mobile phone with an older software version. In this case the user can also initiate the calibration of a mobile phone which has already been used in connection with the hands-free unit.

**[0029]** The test signals should be provided in both locations, the distant terminal and the hands-free system. Depending on the fact which calibration parameter should be determined, different test signals may be used. These different test signals may either be stored in a storage unit provided in both the hands-free system and the distant terminal. However, it is also possible that means for generating the signals are provided. As mentioned above, the test signal may be generated by a shift register used in connection with a time variant attenuation element in order to generate a time variant test signal. Furthermore, means may be provided determining the propagation time or the time delay between the hands-free system and the mobile unit. When this time delay between the different signals is quantified, the two signals can be compared and the corresponding calibration parameters can be determined.

**[0030]** As discussed above, the average signal level of the received test signal can be determined. To this end means for determining the average signal level may be provided.

**[0031]** According to another embodiment of the invention the system may further comprise means for determining whether an automatic feedback control of the signal amplification is carried out in the receiving path of the mobile phone. The system may further comprise means for determining whether a noise reduction is carried out in the receiving path of the mobile phone. Additionally, the system may comprise means for determining whether a signal level limitation is activated in the mobile phone.

#### Brief Description of the Drawings

**[0032]** Other applications and advantages of this invention will become apparent to those skilled in the art upon reference to the specification and the drawings.

Fig. 1 shows an exemplary embodiment of a hands-free system in a vehicle using a calibration in the transmitting and receiving path,

Fig. 2 shows a system for calibrating the receiving path of a hands-free system of a vehicle,

Fig. 3 shows a flowchart incorporating the steps carried out for calibrating the receiving path of a hands-free system,

Fig. 4 shows in further detail a calibration system calculation the calibrating parameters of the calibration system,

Fig. 5 shows a system for calibrating the transmitting path of a hands-free system, and

Fig. 6 shows a flowchart comprising the steps for calibrating the transmitting path of the system shown in Fig. 5.

#### Detailed Description of the Preferred Embodiments

**[0033]** In Fig. 1 a hands-free system used in a vehicle is shown in which a system for calibrating the hands-free system of the invention can be incorporated. The system shown in the vehicle 10 comprises a mobile phone 11. The mobile phone 11 receives audio signals via a telecommunication system not shown in the figure and transmits signals via the telecommunication system. In the embodiment shown in Fig. 1 the mobile phone 11 is used in connection with a hands-free unit 12. In many countries the use of a hands-free systems in vehicles is mandatory in order to avoid the distraction of the driver during driving. The hands-free system can be connected to an audio system of the vehicle, especially to the loudspeakers 13 through which the signal received from the other end of the line is output. Additionally, microphones 14 are provided picking up the voice signal of the user which is transmitted via the hands-free unit to the mobile phone and then to the other end of the line. In order to achieve the best speech quality, the mobile phone 11 has to be adapted to the hands-free unit 12. By way of example each mobile phone may have a different signal level, as the electronic components used in each mobile phone may result in an amplification which is different for each mobile phone. The mobile phone can be adapted to the hands-free unit by a first calibration unit 15 provided in the receiving path and a second calibration unit 16 provided in the transmitting path of the system. The calibration unit provided in the receiving path can be used in

the following example. Normally, the loudspeaker incorporated into the mobile phone is very small, so that the emitted audio signal is largely attenuated at lower frequencies. This attenuation can be reduced when a filter is used removing the attenuation in the lower frequency range. If, however, the loudspeakers of the vehicle are used and if the signal filter in the mobile phone is not deactivated, the audio signal output by the loudspeaker will have strongly reinforced lower signal components as the loudspeaker provided in the vehicle will normally not attenuate the lower frequency components as much as the smaller loudspeaker in the mobile phone. In order to remove this effect, the calibration unit 15 can be used in the receiving path. The calibration unit 16 provided in the transmission path can help to adapt the audio signal to the environment due to the fact that the microphones 14 of the vehicle are used instead of the microphones provided in the mobile phone itself. The calibration unit 16 can adapt the audio signal to be transmitted to the other end of the line taking into account the different frequency responses of the microphones 14 compared to the frequency responses of the microphones (not shown) in the mobile phone itself.

**[0034]** In Fig. 2 a system is shown which can be used for individually calibrating each mobile phone of a hands-free system. When a user of the mobile phone 11 in the vehicle 10 uses the mobile phone in connection with the hands-free unit 12, a detection unit (not shown) can detect when a mobile phone is used for which no calibration has been carried out. The driver of the vehicle may be informed that it is possible to calibrate the used mobile phone to the hands-free system. If the user or driver agrees to the calibration, the system comprising the mobile phone 11 and the hands-free unit 12 will build a connection to a distant terminal 20 via the telephony network of the mobile phone. The system in the vehicle can now initiate a transmission of a test signal stored in a storage unit 21 of the distant terminal 20. The distant terminal also comprises a calibration unit 22 in which the storage unit 21 comprising the different test signals may be provided. The system shown in Fig. 2 comprises a calibration unit 23. The distant terminal 20 transmits a test signal stored in the storage unit 21 to the hands-free system in the vehicle. This transmitted test signal should be a time variant broadband audio signal which is to be transmitted by the telephony network. Preferably, the test signal should be designed in such a way that the transmitted signal is not changed too much by the coding methods of the telephony network, such as GSM or CDMA. Different test signals are recommended by ITU, these test signals normally modeling human speech. By way of example a test signal can be a composite source signal known in the art or an artificial voice signal. The test signals also depend on the storing capacities in the mobile phone or the hands-free unit. If only a limited storage space is provided, it is also possible to use shift registers with feedback and time-dependent attenuation elements for generating the test signal. The test signals provided

in the remote terminal 20 are also provided as reference test signals in the communication system in the vehicle in the storage unit 24.

**[0035]** The test signal from the storage unit 21 is transmitted to the hands-free communication system in the vehicle where it is received by the mobile phone 11. The received test signal is then fed to a comparison unit 25 where the received test signal is compared to the reference test signal stored in the storage unit 24. In order to determine the influence from the receiving mobile phone 11 the reference test signal of the storage unit 24 should be generated the same way as the test signal in the storage unit 21 in the distant terminal 20. In the comparison unit the signal is processed in such a way that the received test signal mainly corresponds to the reference test signal. The calibration parameters determined by the comparison are then fed to the calibration unit 15 provided in the receiving path of the system. In the mobile phone a switch 26 is shown indicating that the transmitted test signal is not output via the loudspeaker 13. The result of comparison is also fed to the hands-free unit 12 for adapting the parameters of the hands-free unit in accordance with the comparison. Additionally, a control unit 27 can be provided controlling the adaption of the hands-free unit 12 and the mobile phone 11 relative to each other. In Fig. 2 the calibration unit 16 for the transmission path of the communication system is shown in dashed lines, as it is not needed for calibration the receiving path of the system containing the hands-free unit and the mobile phone.

**[0036]** In Fig. 3 the steps are summarized which are needed to adapt the receiving path of the hands-free system. After the start of the process in step 31 the hands-free system is connected to the distant terminal. According to one embodiment of the invention the connection is initiated by the hands-free system when it is determined that the connected mobile phone is a mobile phone for which no calibration has been carried out. Furthermore, the hands-free system also determines which of the test signals should be transmitted from the distant terminal to the hands-free system. It is possible that different test signals are transmitted which are needed for adapting the different parameters as will be discussed below. Furthermore, it is possible that only one test signal is transmitted for adapting a certain predetermined calibration parameter of the system. When a connection has been finally built up in step 32, a selected test signal or test signals are transmitted from the distant terminal to the hands-free system in step 33. After receiving the test signal, the latter is compared to the reference test signal stored in storage unit 24 in step 34. In step 35 the calibration parameters are determined by analyzing the received test signal and the reference test signal. When the calibration parameters can be determined, the incoming audio signals can then be processed using the determined calibration parameters. The process ends in step 36.

**[0037]** In Fig. 4 an embodiment of a comparison unit

is shown in more detail. The calibration unit shown in Fig. 4 has two input terminals 41 and 42. The calibration unit receives the reference test signal of the storage unit 24 and receives the signal transmitted from the distant terminal at the input terminal 42. After receiving the two signals, the propagation time can be considered taking into account that one of the two signals was transmitted from a distant terminal. Once the propagation time has been considered, different calibration parameters can be calculated. By way of example a level determination unit 43 can determine the signal level of the two received signals. The level determination unit can determine a time-averaged level of the received signal and compare the time-averaged signal level to the signal level of the reference test signal. The signal level difference between the two signals can then be removed or minimized by adapting the calibration parameters accordingly.

**[0038]** Additionally, it is possible to equalize the receiving signal response. To this end a spectrum determination unit 44 can be provided determining the spectrum of the received signal. The spectrum determination unit 44 can determine the discrete Fourier transform of the two signals, or a linear predictive coding analysis (LPC analysis) can be carried out. When a LPC analysis is used, the equalizing can be obtained by a finite impulse response (FIR) filter or an infinite impulse response (IIR) filter.

**[0039]** Additionally, it is possible to determine whether in the mobile phone the signal amplification is controlled automatically in the receiving path. This can be done by an amplification detection unit 45 detecting whether an automatic control of the signal amplification is carried out in the mobile phone. In this case the test signal can be a signal, the level of which varies during transmission. When this level difference of the incoming test signal is balanced, it is possible to deduce that an automatic level control is carried out in the mobile phone. The signal amplification of the hands-free unit can then be determined accordingly.

**[0040]** Furthermore, the calibration unit shown in Fig. 4 can comprise a limiter detection unit 46 detecting whether in the receiving path of the mobile phone a limiter is present. For detecting the presence of a limiter the test signal may comprise large amplitudes mainly corresponding to the maximum modulation. If a limiter was found to be present in the mobile phone, a possible limiter in the hands-free unit should be either deactivated or adapted accordingly.

**[0041]** Furthermore, a noise reduction unit 47 can be provided detecting whether a noise reduction is carried out in a mobile phone. In one example this can be detected by using a test signal having a predetermined amount of background noise. When the signal-to-noise-ratio is known for the transmitting and for the receiving system, it is possible to deduce whether a noise reduction is active in the mobile phone. The noise reduction in the hands-free unit can then be adapted accordingly. Furthermore, a frequency response determination unit 48

can be provided. The knowledge of the frequency response of the mobile phone can help to furthermore improve the speech quality in the hands-free system, as frequency components not provided in the transmitted signal can be generated using bandwidth extension methods. The calculation of the spectral components which were suppressed by the transmission system is possible with high accuracy when the frequency response of the mobile phone is known. If the frequency response is known, the influence of the receiving path of the mobile phone can be removed by calculating the calibration parameters accordingly. Last but not least a control unit 49 is provided controlling the different units shown in Fig. 4. The calculated calibration or equalizing parameters can then be fed to the calibration unit in the receiving path.

**[0042]** In Fig. 5 a system is shown which could be used for calibrating the transmission path of the mobile communication system. In connection with Fig. 5 reference numerals also shown in Fig. 2 designate the same units having the same function as shown in Fig. 2. In the embodiment shown in Fig. 5 a test signal is selected from the storage unit 24 and is transmitted via the mobile phone 11 to the distant terminal 20. In the distant terminal 20 the calibration unit 22 comprises a comparison unit 51 in which the received signal is compared to the reference test signal stored in the storage unit 21. In the comparison unit 51 the signal processing steps can be carried out as explained in connection with Figs. 2 and 4. By way of example it is possible to compensate signal level differences and to calculate the frequency response of the transmission path of the mobile phone. Also making reference to Fig. 6 the process for calibrating the transmitting path is shown. After starting the processing in step 61 a connection is built up between the hands-free system 10 and the distant terminal 20 in step 62. The test signal selected from the storage unit 24 is then transmitted from the hands-free system to the distant terminals in step 63 where the received test signal is compared to the reference test signal stored in the storage unit 21 (step 64). The calibration or equalization parameters are then determined in step 65 in the comparison unit 51. With the help of a transmission protocol the calculated parameters are then transmitted to the hands-free system in step 66. The calibration parameters are then used in the calibration unit 16 calibrating the transmission path of the hands-free unit and the mobile phone. When the calibration parameters have been stored in the hands-free system, the test signal processed by the calibration parameters can again be sent to the distant terminal. The distant terminal can then verify whether the transmitted test signal substantially corresponds to the reference test signal. If this is not the case the calibration steps can be repeated.

**[0043]** The distant terminal can be a server accessible over the mobile communication system and may be run by the company also manufacturing the hands-free systems. However, the distant terminal can also be run by

any other authority.

**[0044]** Furthermore, it is possible to take into account the mobile telephony network with which the test signals were transmitted. It is possible to store in the transmitted signal the type of network with which the test signal has been transmitted. This can by way of example help when different types of networks are used. By way of example these network changes can occur when the hands-free system is used in connection with a UMTS mobile phone. If a UMTS network is provided, the UMTS network is used. If no UMTS network is provided, a GSM network is used. In this case the calibration parameters determined in connection with the transmission over a UMTS network should not be used for calibrating the system working in a GSM network or vice versa. Accordingly, it is possible to take into account the mobile network through which the test signal is transmitted. The calibration parameters may only be used for the network for which they were determined.

**[0045]** Summarizing this invention provides a possibility to calibrate each used mobile phone and to adapt the mobile phone to a hands-free unit. With the above-described invention it is possible to further improve the speech quality, as the calibration is not limited to the calibration depending on the type of mobile phone used. Instead, a calibration for each individual mobile phone is possible.

## Claims

1. Method for calibrating a hands-free system, the hands-free system comprising a hands-free unit and a mobile phone, the method comprising the following steps:
  - setting up a connection between the hands-free system and a distant terminal via a mobile telephony network of the mobile phone,
  - transmitting a predetermined test signal from one of the hands-free system and the distant terminal to the other of the hands-free system and the distant terminal, the predetermined test signal being provided in both the hands-free system and the distant terminal as reference test signal,
  - comparing the received test signal to the reference test signal stored in the other of the hands-free system and the distant terminal, and
  - determining the calibration parameters of the hands-free system in accordance with the comparison.
2. Method according to claim 1, wherein for calibrating the receiving path of the hands-free system, the predetermined test signal is transmitted from the distant terminal to the hands-free system, the test signal received in the hands-free system is compared to the reference test signal provided in the hands-free system and the calibration parameters of the receiving path of the hands-free system are adapted in accordance with said comparison.
3. Method according to claim 1 or 2, **characterized by** further comprising the step of identifying the mobile phone used in the hands-free system, and if it is detected that a mobile phone is used in the hands-free system for which no calibration has been carried out, the calibration steps are initiated.
4. Method according to any of the preceding claims, wherein the received test signal transmitted from the distant terminal is not output via a loudspeaker of the hands-free system.
5. Method according to any of the preceding claims, wherein a broadband time variant signal is used as test signal, the bandwidth of the test signal corresponding substantially to the bandwidth transmitted by the mobile phone.
6. Method according to claim 5, wherein a composite source signal or an artificial voice signal is used as predetermined test signal.
7. Method according to claim 5, wherein a shift register is used together with a time variant damping element in order to generate the predetermined test signal.
8. Method according to any of the preceding claims, wherein the transmitted test signal and the reference test signal are generated the same way in the distant terminal and the hands-free system.
9. Method according to any of the preceding claims, wherein, before the calibration parameters of the hands-free system are determined, the propagation time difference between the transmitted test signal and the reference test signal provided in the other of the distant terminal and the hands-free system is determined and removed.
10. Method according to any of the preceding claims, wherein a time-averaged signal level of the received signal is determined and compared to the time-averaged signal level of the reference test signal, the calibration parameters being adapted in such a way that the signal level of the received test signal substantially corresponds to the signal level of the reference test signal.
11. Method according to any of the preceding claims, wherein the power density spectrum of the received test signal is determined and compared to the power density spectrum of the stored signal, the equalizing parameters of the hands-free system being deter-



- mined in such a way that the power density spectrum of the received test signal substantially corresponds to the power density of the reference test signal.
12. Method according to any of the preceding claims, wherein it is determined if in the receiving path of the mobile phone an automatic feedback control of the signal amplification is carried out using a test signal with varying signal level, and if the amplification is controlled automatically, the automatic control of the signal amplification in the hands-free system is adjusted in the hands-free system depending on the signal amplification in the mobile phone.
13. Method according to any of the preceding claims, wherein it is determined whether a noise reduction is carried out in the receiving path of the mobile phone by comparing the signal-to-noise-ratio of the received signal to the signal-to-noise-ratio of the provided reference signal, and in the affirmative the noise reduction in the hands-free system is adapted taking into account the noise reduction of the mobile phone.
14. Method according to any of the preceding claims, wherein it is determined whether a signal level limitation is activated in the mobile phone, and in the affirmative, the amount of signal level limitation is determined and the signal level limitation in the hands-free system is adapted taking into account the signal level limitation of the mobile phone.
15. Method according to any of the preceding claims, wherein the frequency response of the mobile phone is determined by comparing the spectrum of the received test signal to the spectrum of the reference test signal, the determined frequency response of the mobile phone being used for extending the bandwidth of the received audio signal of the mobile phone.
16. Method according to any of the claims, wherein when the connection between the hands-free system and the distant terminal is set up, the hands-free system transmits an identification code to the distant terminal and initiates the transmission of the test signal to the hands-free system.
17. Method according to any of the preceding claims, wherein for calibrating the transmission path of the hands-free system, the predetermined test signal is transmitted to the distant terminal where the received signal is compared to the reference test signal provided in the distant terminal, the calibration parameters of the transmitter of the hands-free system being calculated at the distant terminal and transmitted to the hands-free system.
18. Method according to claim 17, wherein for calibrating the transmission path of the hands-free system the loudspeaker of the hands-free system is not activated.
19. System for calibrating a hands-free system, the hands-free system being used in connection with a mobile phone, the system comprising:
- a hands-free system comprising
    - a mobile phone,
    - a loudspeaker outputting a signal received by the mobile phone,
    - at least one microphone picking up a speech signal of a user of the hands-free system,
    - a first storage unit provided in the hands-free system storing a reference test signal,
    - a distant terminal transmitting a test signal to or receiving a test signal from the hands-free system, the distant terminal comprising a second storage unit storing the reference test signal,
- wherein the test signal is transmitted from one of the hands-free system and the distant terminal to the other of the hands-free system and the distant terminal, the system further comprising
- a calibration unit adapting the hands-free system to the used mobile phone, the calibration unit comparing the received test signal to the stored reference test signal and determines the calibrating parameters in accordance with said comparison.
20. System according to claim 19, **characterized by** further comprising means for identifying the mobile phone used in connection with the hands-free system, the calibration unit starting to adapt the mobile phone to the hands-free system when it is detected that a mobile phone is used for which no calibration has been carried out.
21. System according to claim 19 or 20, **characterized by** further comprising means for generating the test signal.
22. System according to any of claims 19 to 21, **characterized by** further comprising means for determining the propagation time between the hands-free system and the mobile unit.
23. System according to any of claims 19 to 22, **characterized by** further comprising means for determin-

ing the average signal level of the received test signal.

24. System according to any of claims 19 to 23, **characterized by** further comprising means for determining the power density spectrum of the received test signal and of the reference test signal. 5
25. System according to any of claims 19 to 24, **characterized by** further comprising means for determining whether an automatic feedback control of the signal amplification is carried out in the receiving path of the mobile phone. 10
26. System according to any of claims 19 to 25, **characterized by** further comprising means for determining whether a noise reduction is carried out in the receiving path of the mobile phone 15
27. System according to any of claims 19 to 21, **characterized by** further comprising means for determining whether a signal level limitation is activated in the mobile phone 20

25

30

35

40

45

50

55

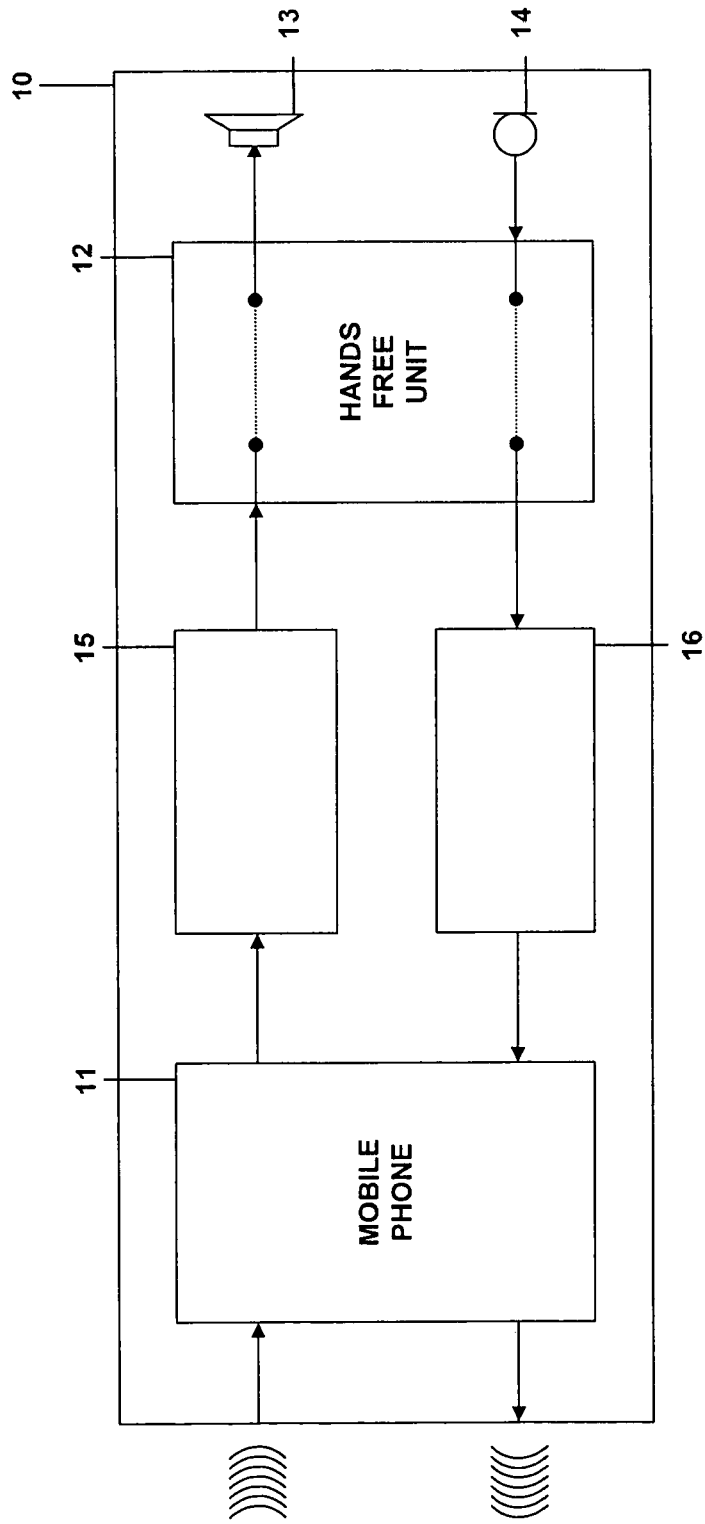

FIG. 1

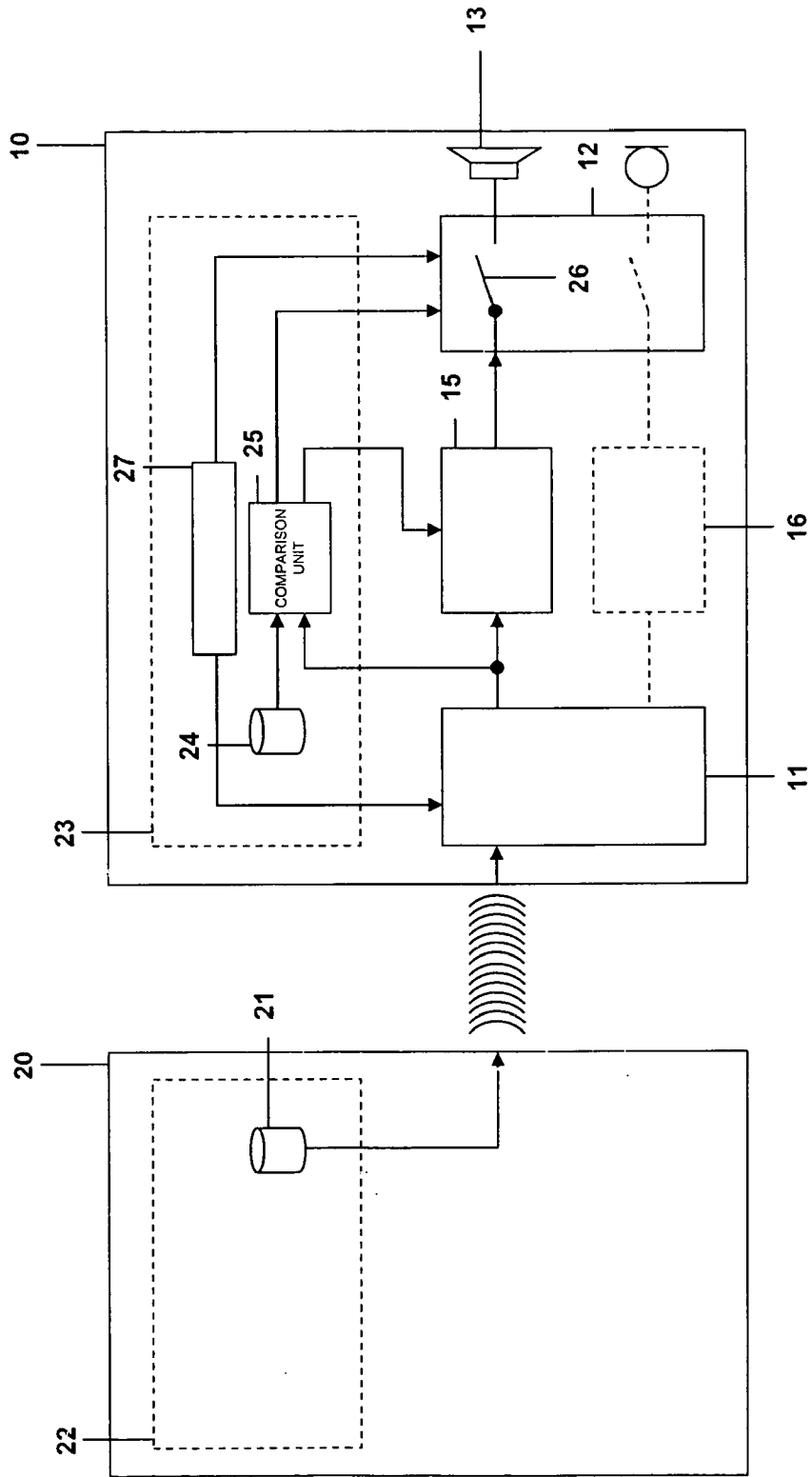

FIG. 2

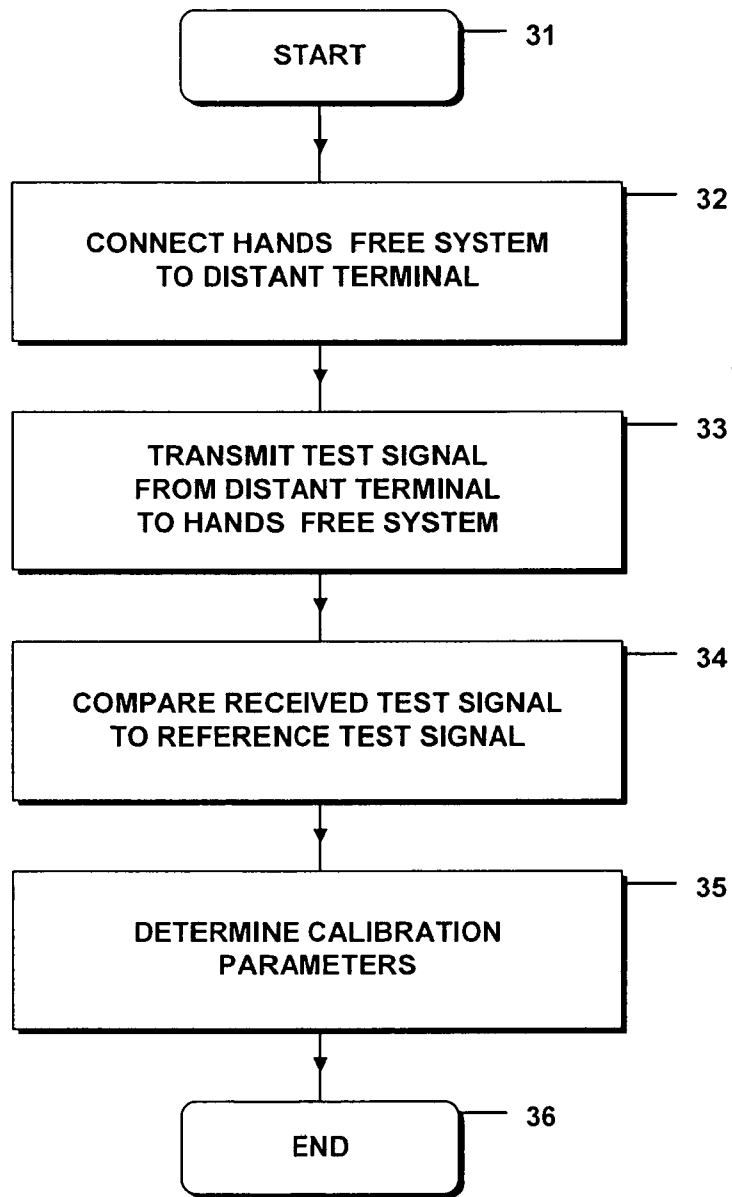

FIG. 3

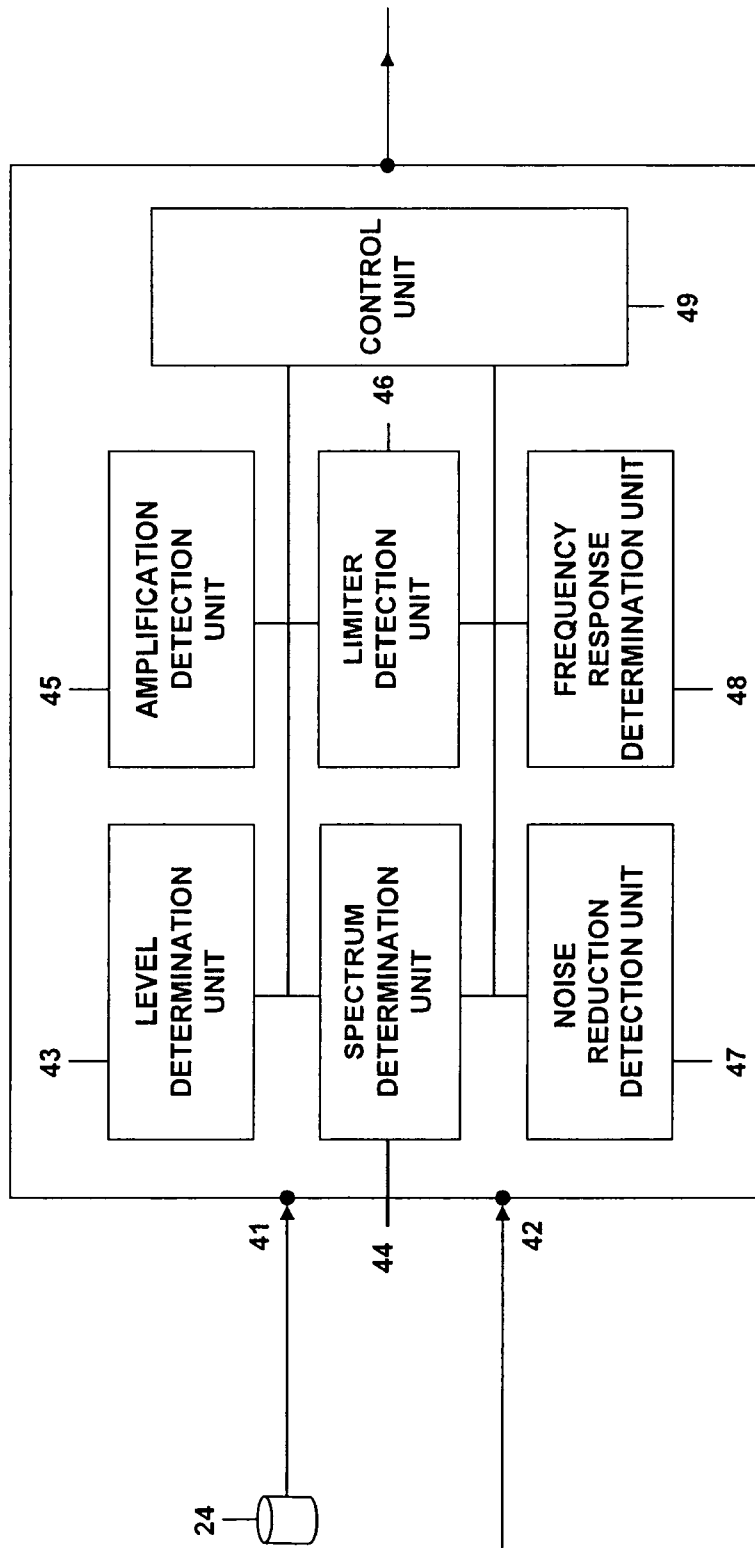

FIG. 4

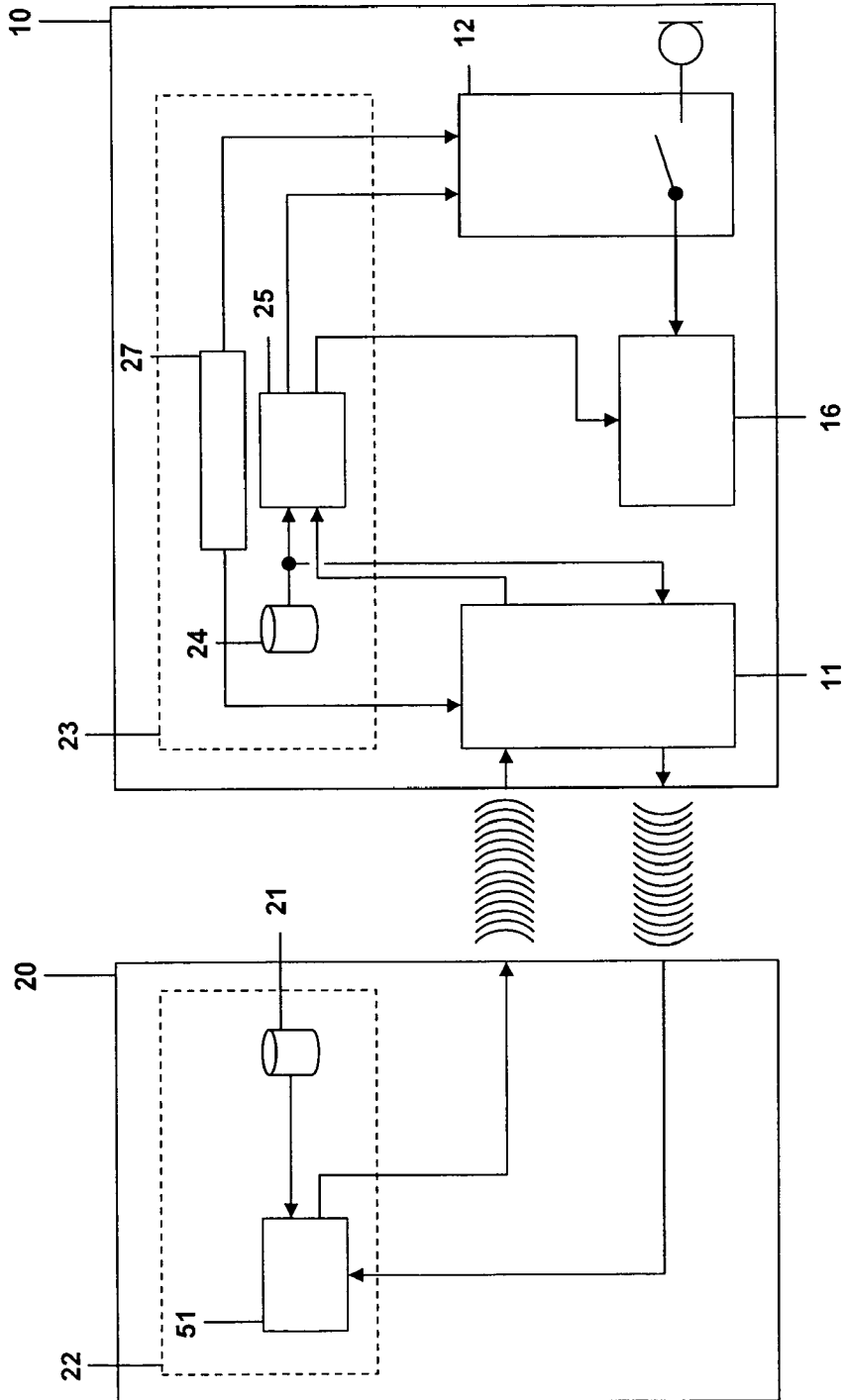

FIG. 5

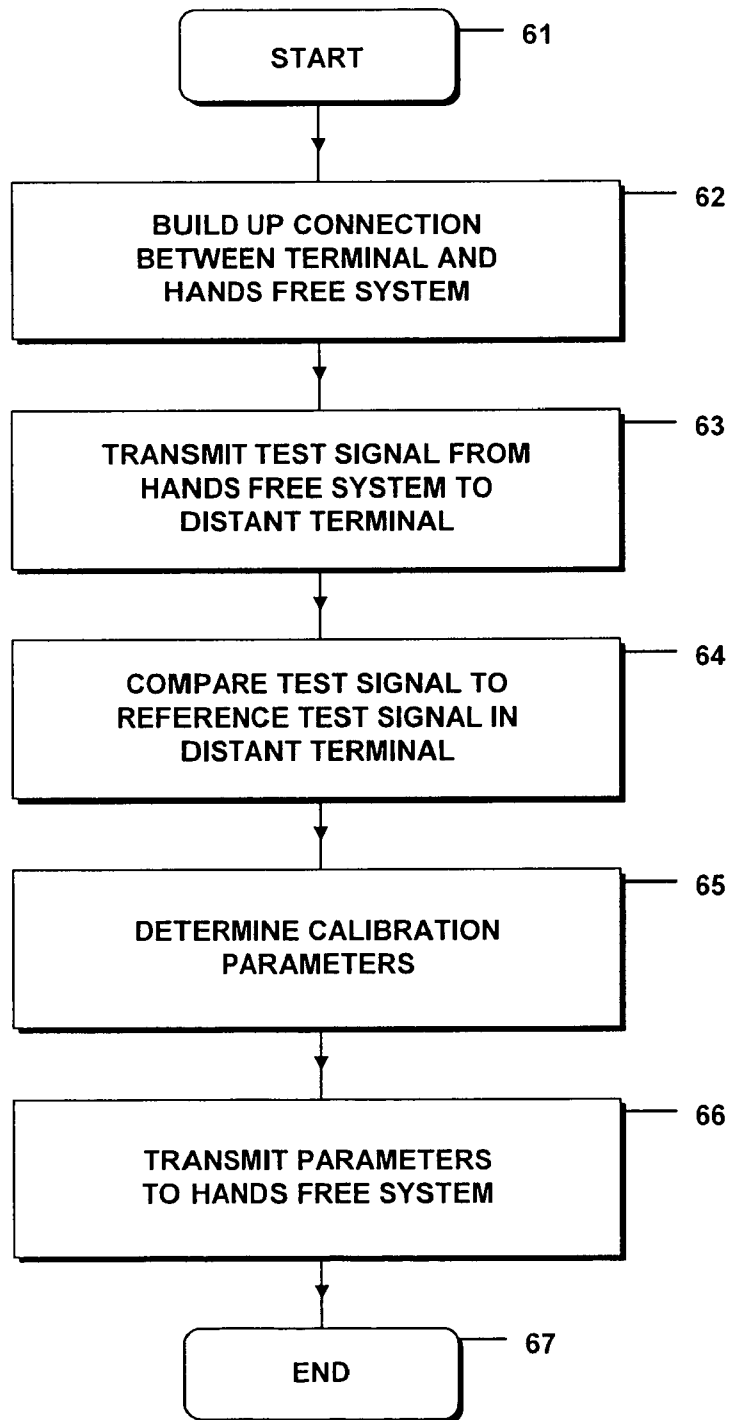

FIG. 6





DOCUMENTS CONSIDERED TO BE RELEVANT			
Category	Citation of document with indication, where appropriate, of relevant passages	Relevant to claim	CLASSIFICATION OF THE APPLICATION (IPC)
X	EP 1 583 265 A (INFINEON TECHNOLOGIES AG [DE]) 5 October 2005 (2005-10-05) * abstract * * paragraph [0005] * * paragraph [0017] - paragraph [0018] * * paragraph [0025] - paragraph [0027] * * paragraph [0031] - paragraph [0033] * * paragraph [0036] * * paragraph [0039] * * claim 1 *	1-27	INV. H04M1/60 H04M1/24
A	FR 2 736 490 A1 (RENAULT [FR]) 10 January 1997 (1997-01-10) * abstract * * page 2, line 28 - page 3, line 13 * * page 7, line 9 - page 8, line 3 *	1,2,19	
A	EP 1 376 997 A (CIT ALCATEL [FR]) 2 January 2004 (2004-01-02) * abstract * * paragraph [0033] - paragraph [0034] *	1,19	
			TECHNICAL FIELDS SEARCHED (IPC)
			H04M H04Q G01R H04B
The present search report has been drawn up for all claims			
Place of search Munich		Date of completion of the search 15 January 2007	Examiner Bianchi, Damiano
CATEGORY OF CITED DOCUMENTS X : particularly relevant if taken alone Y : particularly relevant if combined with another document of the same category A : technological background O : non-written disclosure P : intermediate document		T : theory or principle underlying the invention E : earlier patent document, but published on, or after the filing date D : document cited in the application L : document cited for other reasons & : member of the same patent family, corresponding document	

1  
EPO FORM 1503 03.82 (P04C01)

**ANNEX TO THE EUROPEAN SEARCH REPORT  
ON EUROPEAN PATENT APPLICATION NO.**

EP 06 01 5385

This annex lists the patent family members relating to the patent documents cited in the above-mentioned European search report. The members are as contained in the European Patent Office EDP file on  
The European Patent Office is in no way liable for these particulars which are merely given for the purpose of information.

15-01-2007

Patent document cited in search report		Publication date	Patent family member(s)	Publication date
EP 1583265	A	05-10-2005	CN 1677907 A	05-10-2005
FR 2736490	A1	10-01-1997	NONE	
EP 1376997	A	02-01-2004	US 2003235293 A1	25-12-2003

EPC FORM P0459

For more details about this annex : see Official Journal of the European Patent Office, No. 12/82