



(12) **EUROPEAN PATENT APPLICATION**

(43) Date of publication: **23.07.2008 Bulletin 2008/30** (51) Int Cl.: **G10L 21/02 (2006.01)**

(21) Application number: **07001062.4**

(22) Date of filing: **18.01.2007**

(84) Designated Contracting States:
AT BE BG CH CY CZ DE DK EE ES FI FR GB GR HU IE IS IT LI LT LU LV MC NL PL PT RO SE SI SK TR

Designated Extension States:
AL BA HR MK RS

(71) Applicant: **Harman Becker Automotive Systems GmbH**
76307 Karlsbad (DE)

(72) Inventors:
• **Iser, Bernd**
89077 Ulm (DE)

• **Nüssle, Gerhard**
89134 Blaustein (DE)
• **Schmidt, Gerhard**
89081 Ulm (DE)

(74) Representative: **Grünecker, Kinkeldey, Stockmair & Schwanhäusser**
Anwaltssozietät
Leopoldstrasse 4
80802 München (DE)

(54) **Method and apparatus for providing an acoustic signal with extended band-width**

(57) The invention is directed to a method and an apparatus for providing an acoustic signal with extended bandwidth comprising providing an upper extension signal for extending a received acoustic signal at upper frequencies, wherein providing the upper extension signal

comprises shifting the received acoustic signal at least above a predetermined lower frequency value and/or below a predetermined upper frequency value by a predetermined shifting frequency value to obtain a shifted signal.

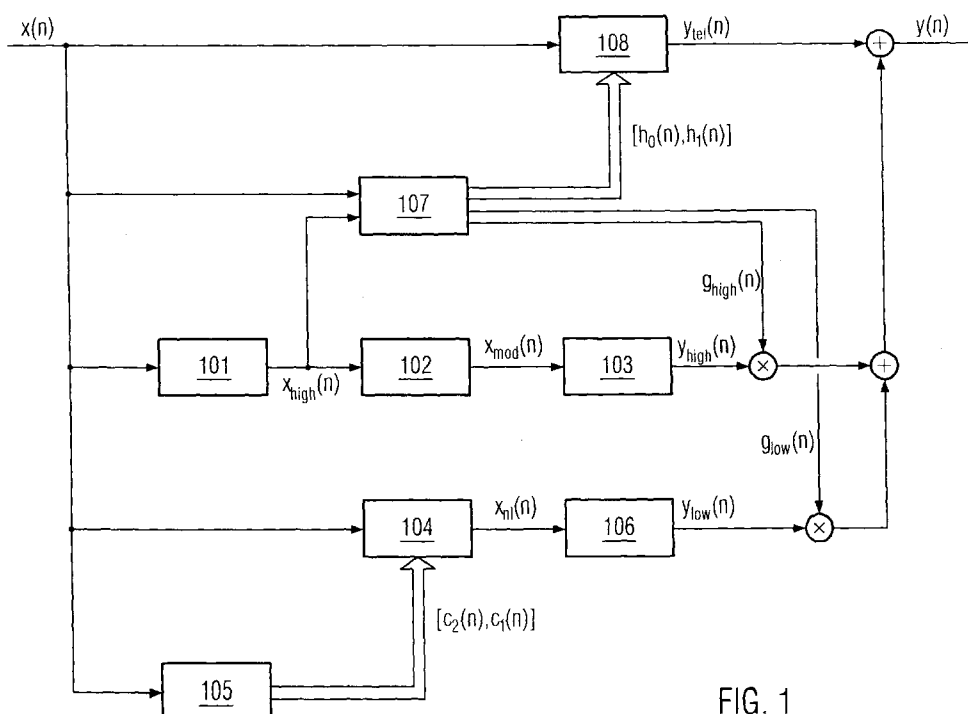

FIG. 1

Description

[0001] The invention is directed to a method and an apparatus for providing an acoustic signal, in particular, a speech signal, with extended bandwidth.

[0002] Acoustic signals transmitted via an analog or digital signal path usually suffer from the drawback that the signal path has only a restricted bandwidth such that the transmitted acoustic signal differs considerably from the original signal. For example, in the case of conventional telephone connections, a sampling rate of 8 kHz is used resulting in a maximal signal bandwidth of 4 kHz. Compared to the case of audio CDs, the speech and audio quality is significantly reduced.

[0003] Furthermore, many kinds of transmissions show additional bandwidth restrictions. In the case of an analog telephone connection, only frequencies between 300 Hz and 3.4 kHz are transmitted. As a result, only 3.1 kHz bandwidths are available.

[0004] In the case of speech signals, for example, the lack of high frequencies has the consequence that the comprehensibility is reduced. Furthermore, due to missing low frequency components, the speech quality is reduced.

[0005] In principle, the bandwidth of telephone connections could be increased by using broadband or wideband digital coding and de-coding methods (so called broadband codecs). In such a case, however, both the transmitter and the receiver have to support corresponding coding and de-coding methods which would require the implementation of a new standard.

[0006] As an alternative, systems for bandwidth extension can be used as described, for example, in P. Jax, Enhancement of Bandwidth Limited Speech Signals: Algorithms and Theoretical Bounds, Dissertation, Aachen, Germany, 2002 or E. Larsen, R.M. Aarts, Audio Bandwidth Extension, Wiley, Hoboken, NJ, USA, 2004. These systems are to be implemented on the receiver's side only such that existing telephone connections do not have to be changed. In these systems, the missing frequency components of the input signal with small bandwidths are estimated and added to the input signal.

An example of the structure and the corresponding signal flow in such a state of the art bandwidth extension system is illustrated in Figure 8. In general, the missing frequency components are re-synthesized blockwise.

[0007] At block 801, an incoming or received signal $x(n)$ in digitized form is processed by an analysis filter bank so

as to obtain spectral vectors $X(e^{j\Omega_\mu}, n)$. Here, the variable n denotes the time. In this Figure, it is assumed that the incoming signal $x(n)$ has already been converted to the desired bandwidth by increasing the sampling rate. In this conversion step, no additional frequency components are to be generated which can be achieved, for example, by using appropriate anti-aliasing or anti-imaging filtering elements. In order not to amend the transmitted signal, the bandwidth extension is performed only within the missing frequency ranges. Depending on the transmission method, the extension concerns low frequency (for example from 0 to 300 Hz) and/or high frequency (for example 3400 Hz to half of the desired sampling rate) ranges.

[0008] In block 802, a narrowband spectral envelope is extracted from the narrowband signal, the narrowband signal being restricted by the bandwidth restrictions of a telephone channel, for example. Via a non-linear mapping, a corresponding broadband envelope is estimated from the narrowband envelope. The mappings are based, for example, on codebook pairs (see J. Epps, W.H. Holmes, A New Technique for Wideband Enhancement of Coded Narrowband Speech, IEEE Workshop on Speech Coding, Conference Proceedings, Pages 174 to 176, June 1999) or on neural networks (see J.-M. Valin, R. Lefebvre, Bandwidth Extension of Narrowband Speech for Low Bit-Rate Wideband Coding, IEEE Workshop on Speech Coding, Conference Proceedings, Pages 130 to 132, September 2000). In these methods, the entries of the codebooks or the weights of the new networks are generated using training methods requiring large processor and memory resources.

[0009] Furthermore, in block 803, a broadband or wideband excitation signal $X_{exc}(e^{j\Omega_\mu}, n)$ having a spectrally flat envelope is generated from the narrowband signal. This excitation signal corresponds to the signal which would be recorded directly behind the vocal chords, i.e. the excitation signal contains information about voicing and pitch, but not about form and structures or the spectral shaping in general (see, for example, B. Iser, G. Schmidt, Bandwidth Extension of Telephony Speech, EURASIP Newsletter, Volume 16, Number 2, Pages 2 to 24, June 2005).

[0010] Thus, to retrieve a complete signal, such as a speech signal, the excitation signal has to be weighted with the spectral envelope. For the generation of excitation signals, nonlinear characteristics (see U. Kornagel, Spectral Widening of the Excitation Signal for Telephone-Band Speech Enhancement, IWAENC '01, Conference Proceedings, Pages 215 to 218, September 2001) such as two-way rectifying or squaring, for example, may be used. For bandwidth extension,

the excitation signal $X_{exc}(e^{j\Omega_\mu}, n)$ is spectrally colored using the envelope in block 804.

[0011] After that, the spectral ranges used for the extension are extracted using a band stop filter in block 806 resulting

in signal spectrum $Y_{ext}(e^{j\Omega_\mu}, n)$. The band stop filter can be effective, for example, in the range from 200 to 3700 Hz.

5 [0012] The spectra $X(e^{j\Omega_\mu}, n)$ of the received signal are passed through a complementary bandpass filter in block

805. Then, the signal components $Y_{ext}(e^{j\Omega_\mu}, n)$ and $Y_{tel}(e^{j\Omega_\mu}, n)$ are added to obtain a spectrum $Y(e^{j\Omega_\mu}, n)$ with extended bandwidth. In block 807, the different spectra are assembled again in a synthesis filter bank to yield the output signal $y(n)$ having an extended bandwidth.

10 [0013] Additional elements might be present in the system, for example, to perform a preemphasis and/or a de-emphasis step or to adapt the power of the spectra $Y_{ext}(e^{j\Omega_\mu}, n)$ and $Y_{tel}(e^{j\Omega_\mu}, n)$. In many cases, the signal processing is performed in the sub band or frequency domain.

15 [0014] In the prior art systems, the signal parameters such as fundamental speech frequency, mean power, spectral envelope, etc., are determined for whole blocks of sampling values. At least for a block, these parameters remain unchanged. From these parameters, the extension signal and the broadband spectral envelope are generated. In the last step, subsequent blocks with an overlap of 50 to 75 percent are combined and the spectrally extended output signal is created. This results in a typical block offset of about 5 to 10 ms in case of an overall block length of about 20 ms.

20 [0015] This has the consequence that significant artifacts occur in case of strongly varying speech signal passages. Furthermore, due to the block processing, a delay is inserted into the signal path. Particularly, in the case of handsfree systems, also the transmitter path shows a delayed signal processing. In such a case, the sum of these delays would yield overall delay values that are larger than the maximum values proposed by ETSI (ETS 300 903 (GSM 03.50), Transmission Planning Aspects of the Speech Service in the GSM Public Land Mobile Network (PLMS) System, ETSI, France, 1999) or ITU (ITU-T Recommendation G. 167, General Characteristics of International Telephone Connections and International Telephone Circuits - Acoustic Echo Controllers, Helsinki, Finland, 1993). In particular for fixedly mounted telephones or for handsfree systems, the maximum delay due to additional signal processing should be 2 ms. However, this cannot be achieved with the prior art systems described above.

25 [0016] Therefore, it is an object underlying the present invention to provide a method and an apparatus for providing an acoustic signal with extended bandwidth, wherein the above disadvantages are overcome and, in particular, the signal delay is reduced.

30 [0017] This object is achieved by the method according to claim 1 and the apparatus according to claim 25.

[0018] Accordingly, the invention provides a method for providing an acoustic signal with extended bandwidth, comprising providing an upper extension signal for extending a received acoustic signal at upper frequencies, wherein providing the upper extension signal comprises shifting the received acoustic signal at least above a predetermined lower frequency value and/or below a predetermined upper frequency value by a predetermined shifting frequency value to obtain the shifted signal.

35 [0019] As the extension signal is provided based on shifting the received acoustic signal, i.e. by providing a shifted copy of the received signal, no block based signal processing is needed. Therefore, the delay occurring during signal processing is reduced compared to the case of the above block based processing.

40 [0020] For obtaining the upper extension signal, the received acoustic signal over its full range may be shifted. Alternatively, only part of the received acoustic signal in the sense that the received acoustic signal above a predetermined lower frequency value and/or below a predetermined upper frequency value may be shifted.

[0021] In the above formulation, the term "at upper frequencies" does not necessarily denote a predefined frequency range but rather indicates that the received acoustic signal is extended or complemented at frequencies lying in the upper frequency range of and/or above the frequency range of the received acoustic signal.

45 [0022] In principle, the obtained shifted signal may be taken as upper extension signal. However, additional processing of the shifted signal is possible as well. The predetermined shifting frequency value may be chosen so that the shifted signal covers a frequency range suitable for complementing the received acoustic signal.

[0023] The received acoustic signal may be a digital signal or may be digitized.

50 [0024] In the above method, the step of shifting may be preceded by high-pass filtering the received acoustic signal.

[0025] This is particularly useful in order to avoid that the signal resulting from shifting the received acoustic signal overlaps with the received acoustic signal. By performing such a high-pass filtering, the received acoustic signal is shifted only as far as it is above the predetermined lower frequency which is the cutoff frequency of the high-pass filter; thus, overlap of the shifted signal and the received acoustic signal can be avoided.

55 [0026] In the above methods, the step of shifting may be followed by high-pass filtering the shifted signal to obtain a filtered shifted signal.

[0027] Such a subsequent high-pass filtering further ensures that components of the shifted signal that would overlap with the original received acoustic signal will be removed. The filtered shifted signal may be taken as upper extension

signal. However, additional processing of the filtered shifted signal is possible as well.

[0028] The cutoff frequency of a high-pass filter for high-pass filtering the shifted signal may correspond to the cutoff frequency of the high-pass filter filtering the received acoustic signal plus the predetermined shifting frequency value. This is a particularly advantageous choice for avoiding the shifted signal and the received acoustic signal overlap.

5 [0029] In the above described methods, high-pass filtering the received acoustic signal and/or high-pass filtering the shifted signal may be performed using a recursive filter, in particular, a Chebyshev and/or a Butterworth filter.

[0030] These IIR filters allow for an efficient implementation of the high-pass filters.

[0031] The step of shifting may comprise performing a cosine modulation of the received signal. Such a modulation results in an efficient and reliable shifting of the received acoustic signal.

10 [0032] The cosine modulation is obtained by performing a multiplication of the received acoustic signal with a modulation function, namely a cosine function having the product of the shifting frequency and the time variable as arguments.

[0033] As a cosine modulation results in a signal being shifted both in positive and negative frequency directions, high-pass filtering the received acoustic signal before and after performing the cosine modulation is particularly advantageous.

15 [0034] The above methods may further comprise combining the received acoustic signal and the upper extension signal by providing a weighted sum of the received acoustic signal and the upper extension signal.

[0035] In this way, an acoustic signal with extended bandwidth, particularly with regard to the upper frequencies, is finally obtained. The upper extension signal may be the shifted signal or the filtered shifted signal, for example, as mentioned above.

20 [0036] The weights of the weighted sum may be time dependent. This improves the resulting signal quality and reduces the occurrence of artifacts.

[0037] The upper extension signal may be weighted with a first factor, wherein the first factor is a function of an estimated signal-to-noise ratio of the received acoustic signal.

25 [0038] The signal-to-noise ratio (SNR) is a suitable variable for determining whether the received acoustic signal comprises a wanted signal, particularly a speech signal. In this way, a damping or an amplification may be achieved via the weighting depending on whether a wanted signal is present or not in the received acoustic signal. The estimated signal-to-noise ratio may be based on an estimation of the absolute value or modulus of the noise level via an IIR smoothing of first order of the absolute value of the received acoustic signal and possibly of the high-pass filtered received acoustic signal.

30 [0039] In particular, the first factor may be a monotonically increasing function of the estimated signal-to-noise ratio of the received acoustic signal. In this way, a damping of the upper extension signal is performed if the received acoustic signal shows a small signal-to-noise ratio which corresponds to parts of the signal where no speech component is present. If the received acoustic signal shows a larger signal-to-noise ratio, the damping of the upper extension signal is reduced, possibly up to zero damping.

35 [0040] The upper extension signal may be weighted with a second factor, wherein the second factor is a function of an estimated noise level in the upper extension signal.

[0041] In this way, damping of the upper extension signal can be performed depending on the noise level at high frequencies. The second factor can be used alternatively or additionally to the first factor. If both factors are used, preferably, a product of the first and the second factor will be employed.

40 [0042] The second factor may be a monotonically decreasing function of the estimated noise level in the upper extension signal. In this way, more damping is performed if the noise level at high frequencies is high.

[0043] In the above methods, the estimated signal-to-noise ratio and/or the estimated noise level may be estimated based on the respective short time signal power. This is a particularly efficient and reliable way for such an estimation.

45 [0044] In the above methods, the upper extension signal may be weighted with a third factor, wherein the third factor is controlled based on the ratio of an estimated signal level of the received acoustic signal to an estimated signal level of the upper extension signal.

[0045] This allows to more suitably deal with the case that most of the signal power is actually present at low frequencies; in such a case, a damping of the upper extension signal may be appropriate to yield a more natural extended signal.

50 [0046] The third factor may be a monotonically increasing function of the ratio of the estimated signal level of the received acoustic signal to the estimated signal level of the upper extension signal. This has the consequence that a damping of the upper extension signal is performed if most of the signal power is present at low frequencies.

[0047] With regard to the third factor, it is to be noted that it may be used alternatively or additionally to the first or second factors. In particular, the weight of the upper extension signal may be a product of the first factor, the second factor and/or the third factor.

55 [0048] In the methods described above, the received acoustic signal may be weighted by providing a weighted sum of the received acoustic signal at a current time and at the current time minus one time step. By taking into account the received acoustic signal both at the current time and one time step before, it turned out that the resulting signal sounded more harmonic. The time steps depend on the sampling rate of the signal.

[0049] In particular, the weights of the weighted sum of the received acoustic signal at the current time and at the current time minus one time step may be functions of an estimated signal-to-noise ratio of the received acoustic signal and/or of an estimated noise level in the upper extension signal.

5 [0050] By modifying the received acoustic signal in this way, after combining the received acoustic signal and the upper extension signal, a more natural extended signal is obtained. In particular, the weights may be functions of or depend on the first and second factors mentioned above.

[0051] The previously described methods may further comprise providing a lower extension signal for extending the received signal at lower frequencies. By adding low frequency components, particularly an improved speech quality will be obtained.

10 [0052] Providing a lower extension signal may comprise applying a non-linear, in particular, a quadratic, characteristic on the received acoustic signal. In other words, applying a quadratic characteristic, for example, would be represented by a weighted sum of the received acoustic signal and the square of the received acoustic signal. By using a non-linear characteristic, harmonics are created so that missing frequencies may be obtained.

15 [0053] The non-linear characteristic may be time dependent. Thus, the parameters of the non-linear characteristic are time dependent. In particular, in the case of a quadratic characteristic, the weights or factors would be time dependent.

[0054] Applying a non-linear characteristic may be followed by band-pass filtering the resulting signal. Band-pass filtering the signal after applying the characteristic allows to provide a lower extension signal in which components below a predetermined frequency value, such as the fundamental speech frequency, and/or above the minimal frequency of the received acoustic signal have been removed in order to avoid disturbances in the resulting extended signal.

20 [0055] The above methods may further comprise combining the received acoustic signal and the lower extension signal by providing a weighted sum of the received acoustic signal and the lower extension signal.

[0056] The lower extension signal may be weighted with a fourth factor, wherein the fourth factor is a function of an estimated signal-to-noise ratio of the received acoustic signal. In particular, the fourth factor may be a function of the first factor mentioned above.

25 [0057] The invention further provides a computer program product comprising one or more computer readable media having computer executable instructions for performing the steps of the method of one of the preceding claims when run on a computer.

30 [0058] Furthermore, the invention provides an apparatus for providing an acoustic signal with extended bandwidth, comprising means for providing an upper extension signal for extending a received acoustic signal at upper frequencies, wherein the means for providing the upper extension signal is configured to shift the received acoustic signal at least above a predetermined lower frequency value and/or below a predetermined upper frequency value by a predetermined shifting frequency value to obtain a shifted signal.

[0059] The means for providing an upper extension signal may be further configured to perform the steps of one of the methods mentioned above.

35 [0060] Additional aspects will be described in the following with reference to the figures and illustrative examples.

Figure 1 illustrates schematically an example of the signal flow for a method for providing an acoustic signal with extended bandwidth;

40 Figure 2 shows the modulus of frequency responses of examples of high-pass filters;

Figure 3 shows the modulus of the frequency response of an example of a band-pass filter;

45 Figure 4 illustrates an example of a speech signal and corresponding short time power estimations;

Figure 5 shows an example of a received acoustic signal and a corresponding damping factor;

Figure 6 shows the modulus of frequency responses for an example of an adaptive high-pass filter;

50 Figure 7 illustrates an example of a received acoustic signal and a corresponding signal with extended bandwidth;

Figure 8 illustrates an example of a prior art method.

55 [0061] Figure 1 illustrates an example of the signal flow for a method for providing an acoustic signal with extended bandwidth. In the illustrated example, an extension both for upper and lower frequencies is performed. However, providing an upper extension signal and providing a lower extension signal are, in principle, independent of each other. Thus, it is also possible to provide only one of the extension signals.

[0062] The method is performed on a received acoustic signal $x(n)$, wherein the signal is a digital or a digitized signal

and n denotes the time variable.

[0063] As will be outlined in more detail in the following, an upper extension signal $y_{high}(n)$ is obtained by passing the received acoustic signal $x(n)$ through a high-pass filter 101, performing a spectral shifting in block 102, and passing the shifted signal through a high-pass filter 103.

[0064] Spectrally shifting is performed in block 102 by performing a cosine modulation. In the present example, a modulation frequency Ω_0 of approximately 1380 Hz is used. If the sampling frequency for the acoustic signal is $f_s = 11,025 \text{ Hz}$, only $N_{mod} = 8$ cosine values have to be stored. As a cosine modulation performs a frequency shift in both a positive and a negative frequency direction

$$FT\{x(n) \cos(\Omega_0 n)\} = \frac{1}{2} X(e^{j(\Omega+\Omega_0)}) + \frac{1}{2} X(e^{j(\Omega-\Omega_0)})$$

a high-pass filtering is performed in block 101 in order to avoid that the shifted spectra overlap.

[0065] As high-pass filter 101, a recursive filter with the difference equation

$$x_{high}(n) = \sum_{k=0}^{N_{hp,1}} b_{hp,1,k} x(n-k) + \sum_{k=1}^{\tilde{N}_{hp,1}} a_{hp,1,k} x_{high}(n-k)$$

is used. The order of the filter both in the FIR and the IIR part may range from 4 to 7. In particular, one can use

$$N_{hp,1} = \tilde{N}_{hp,1} = 6$$

[0066] The resulting modulus of the frequency response of such a high-pass filter is shown in Figure 2 (solid line).

[0067] If, for example, the received acoustic signal (input signal) contains only signal components up to 4 kHz, the resulting signal $x_{high}(n)$ will essentially contain relevant signal components only between approximately 2 kHz to 4 kHz.

[0068] In block 102, this signal is now multiplied with a cosine function

$$x_{mod}(n) = x_{high}(n) \cos(\Omega_0 \text{ mod}(n, N_{mod}))$$

wherein $\text{mod}(n, N_{mod})$ designates a modular addressing. If the modulation frequency Ω_0 is chosen to be 1380 Hz (see above) and the sampling frequency is 11025 Hz, only $N_{mod} = 8$ cosine values are necessary. As the cosine modulation also results in a frequency shift to lower frequencies, a second high-pass filter 103 is applied on the modulated signal $x_{mod}(n)$;

$$y_{high}(n) = \sum_{k=0}^{N_{hp,2}} b_{hp,2,k} x_{mod}(n-k) + \sum_{k=1}^{\tilde{N}_{hp,1}} a_{hp,2,k} y_{high}(n-k).$$

[0069] The order of the second high-pass filter may but need not be identical to the case of the first high-pass filter. However, also in this case it is desirable to choose

$$N_{hp,2} = \tilde{N}_{hp,2} = 6.$$

[0070] The high-pass filter has been designed such that the transition range starts at approximately 3400 Hz. Figure 2 (dashed line) shows the modulus of the frequency response of the second high-pass filter. Other transition ranges are possible as well, particularly depending on the bandwidth of the received acoustic signal.

[0071] A lower extension signal is obtained by applying a non-linear quadratic characteristic to the received acoustic signal $x(n)$ in block 104. The coefficients for this non-linear characteristic are determined in block 105. For this, first of all, the short time maximum $x_{\max}(n)$ of the modulus of the received acoustic signal is estimated. This may be done recursively:

$$x_{\max}(n) = \begin{cases} \max \{K_{\max}|x(n)|, \kappa_{inc}x_{\max}(n-1)\}, & \text{if } |x(n)| > x_{\max}(n-1), \\ \kappa_{dec}x_{\max}(n-1) & \text{else.} \end{cases}$$

[0072] For the constants κ_{dec} and κ_{inc} used in this estimation, the following condition may be taken:

$$0 < \kappa_{dec} < 1 < \kappa_{inc}.$$

[0073] The constant K_{\max} may be chosen from the interval

$$0.25 < K_{\max} < 4.$$

[0074] As an example, the following particular values can be chosen:

$$K_{\max} = 0.8,$$

$$\kappa_{inc} = 1.05,$$

$$\kappa_{dec} = 0.995.$$

[0075] According to a particular example, the non-linear characteristic may be a quadratic characteristic with time dependent coefficients.

$$x_{nl}(n) = c_2(n)x^2(n) + c_1(n)x(n).$$

[0076] A respective of what kind of non-linear characteristic is used, the non-linearity allows to generate signal component at frequencies which have not been present. Using power characteristics allows for signal components consisting of multiples of a fundamental frequency to generate only harmonics or missing fundamental waves.

[0077] In principle, the coefficients need not be time dependent. However, when using time dependent coefficients, changes of the signal dynamic due to the characteristics can be compensated for. In particular, the coefficients may be adapted to the current input signal such that only a small change in power from input signal to output signal is allowed. As an example, the coefficients can be chosen as follows:

$$c_2(n) = \frac{K_{nl,2}}{g_{\max} x_{\max}(n) + \varepsilon},$$

5

$$c_1(n) = K_{nl,1} - c_2(n)x_{\max}(n).$$

10

[0078] The constant ε is used to avoid division by zero. The other constants may take the following exemplary values:

15

$$K_{nl,1} = 1.2,$$

20

$$K_{nl,2} = 1,$$

25

$$g_{\max} = 2,$$

$$\varepsilon = 10^{-5}.$$

30 [0079] The output signal $x_{nl}(n)$ of the adaptive quadratic characteristic comprises the desired low frequency signal components. In addition, however, additional components in the telephone band (such as between 300 Hz and 3400 Hz) and below the fundamental speech frequency (such as below 100 Hz) may be present. In order to remove these components, a band pass filtering is performed in block 106.

35 [0080] In particular, low frequency disturbances may be removed using an IIR filter, such as a Butterworth filter of first order. The output signal of such a high-pass filter are

$$\tilde{x}_{nl}(n) = b_{hp}(x_{nl}(n-1) - x_{nl}(n)) + a_{hp}\tilde{x}_{nl}(n-1)$$

40

wherein the filter coefficients may take the following values

45

$$a_{hp} = 0.95,$$

50

$$b_{hp} = 0.99.$$

[0081] Signal components at high frequencies, such as in the telephone band, may be removed using an IIR filter of higher order:

55

$$y_{low}(n) = \sum_{i=0}^{N_{lp}} b_{hp,i} \tilde{x}_{nl}(n-i) + \sum_{i=1}^{\tilde{N}_{lp}} a_{hp,i} y_{low}(n-i)$$

5

[0082] As an example, Chebyshev low-pass filters of the order $N_{lp} = \tilde{N}_{lp} = 4, \dots, 7$ may be employed.

[0083] A combination of such a high-pass and low-pass filter results in a band-pass filter having a frequency response as illustrated, for example, in Figure 3.

10 [0084] When combining the received acoustic signal and the upper extension signal and/or the lower extension signal, one may take into account whether the received acoustic signal comprises wanted signal components, such as a speech signal, or not. Furthermore, disturbances in the received acoustic signal may be taken into account as well. In view of this, the resulting output signal with extended bandwidth is provided as a weighted sum of the received acoustic signal, the upper extension signal and/or the lower extension signal. Preferably, the weights are chosen to be time dependent.

15 [0085] In the following, examples for suitable weights will be discussed. For these exemplary weights, an estimation of the short time power of the received acoustic signal and of the upper extension signal will be used.

[0086] For this purpose, an IIR smoothing of first order of the modulus of the signals $x(n)$ and $x_{high}(n)$ is performed:

20

$$\overline{x(n)} = \beta_x |x(n)| + (1 - \beta_x) \overline{x(n-1)},$$

25

$$\overline{x_{high}(n)} = \beta_x |x_{high}(n)| + (1 - \beta_x) \overline{x_{high}(n-1)}.$$

[0087] The time constant β_x is chosen to be

30

$$0 < \beta_x \leq 1.$$

[0088] In particular, this constant may take the value of 0.01. From these short time smoothed values, estimations for the noise level can be determined as

35

$$\overline{b(n)} = \max \left\{ b_{\min}, \min \left\{ \overline{x(n)}, \overline{b(n-1)}(1 + \varepsilon) \right\} \right\}$$

40

$$\overline{b_{high}(n)} = \max \left\{ b_{\min}, \min \left\{ \overline{x_{high}(n)}, \overline{b_{high}(n-1)}(1 + \varepsilon) \right\} \right\}.$$

45

[0089] In this case, the constant ε should fulfill

50

$$0 < \varepsilon \ll 1.$$

[0090] In particular, this constant may take the value of 0.00005.

[0091] The constant b_{\min} in the above equations is to avoid that the estimation will reach the value 0 and stop at that point. If the signals are quantized with 16 bit, they lie in the amplitude range

55

$$-2^{15} \leq x(n) < 2^{15}$$

5 [0092] For this modulation range, one may choose $b_{\min} = 0.01$. Figure 4 illustrates an example of an input signal (received acoustic signal) in the upper part. In the lower part, the estimated short time power $\overline{x(n)}$ and of the received signal and the resulting noise power estimation $\overline{b(n)}$ (dashed line) are shown.

10 [0093] The short time power estimated in this way can now be used to determine different factors for weighting the signal components. A first factor $g_{snr}(n)$ is a function of an estimated signal-to-noise ratio. This factor is used to damp the upper extension signal in case of speech passages, i.e. if the signal-to-noise ratio is low. In case of speech signals having a high signal-to-noise ratio, no or almost no damping is to be performed. This can be achieved, for example, by

$$15 \quad g_{snr}(n) = \begin{cases} \beta_{snr} g_{snr, \max} + (1 - \beta_{snr}) g_{snr}(n-1), & \text{if } \overline{x(n)} > K_{snr} \overline{b(n)}, \\ \beta_{snr} g_{snr, \min} + (1 - \beta_{snr}) g_{snr}(n-1), & \text{else.} \end{cases}$$

20 [0094] The parameters $g_{snr, \max}$ and $g_{snr, \min}$ correspond to the maximal and minimal damping. As an example, these parameters may take the values

$$25 \quad g_{snr, \max} = 1$$

$$30 \quad g_{snr, \min} = 0.3.$$

[0095] As a threshold for switching the damping value,

$$35 \quad K_{snr} = 3$$

has been chosen. In other words, the estimated signal power has to exceed the estimated noise power by approximately 10 dB in order to reduce the damping. The time constant of the IIR smoothing is chosen from the interval

$$40 \quad 0 < \beta_{snr} \leq 1$$

45 so as to obtain a stable smoothing filter. In particular, this constant may be chosen to be 0.005.

[0096] Figure 5 illustrates an example of an input signal $x(n)$ (upper part) and the resulting damping factor $g_{snr}(n)$ in dB. As one can see, during speech pauses, the damping is increasing.

[0097] In order to obtain a more natural output signal, a second factor is used to account for high input background noise levels. This second factor $g_{noise}(n)$ is increased if the noise level in the upper extension signal exceeds a predefined threshold. Furthermore, one may implement an hysteresis to avoid that the factor varies to largely.

50 [0098] As an example, the factor $g_{noise}(n)$ can be determined as follows

55

$$g_{noise}(n) = \begin{cases} \min\{1, g_{noise}(n-1)\Delta_{inc}\}, & \text{if } \overline{b_{high}(n)} < \overline{b_0} K_b, \\ \max\{g_{noise,min}, g_{noise}(n-1)\Delta_{dec}\}, & \text{if } \overline{b_{high}(n)} K_b > \overline{b_0}, \\ g_{noise}(n-1), & \text{else.} \end{cases}$$

[0099] The constant $g_{noise,min}$ corresponding to maximal damping, is taken to be 40 dB, in other words

$$g_{noise,min} = 0.01.$$

[0100] For a hysteresis of approximately 6 dB, one has to take

$$K_b = 1.4$$

[0101] The additional factors fulfill

$$0 < \Delta_{dec} < 1 < \Delta_{inc}.$$

[0102] According to a preferred example, one may take

$$\Delta_{dec} = 0.9999,$$

$$\Delta_{inc} = 1.0001.$$

[0103] In this way, a maximal correction of about 10 dB/s is obtained.

[0104] A third factor $g_{hr}(n)$ may be used for the upper extension signal to damp the upper extension signal in cases when most of the signal power is present at low frequencies. This can be achieved by

$$g_{hr}(n) = \begin{cases} \beta_{hr} g_{hr,max} + (1 - \beta_{hr}) g_{hr}(n-1), & \text{if } \overline{x(n)} < K_{hr} \overline{x_{high}(n)}, \\ \beta_{hr} g_{hr,min} + (1 - \beta_{hr}) g_{hr}(n-1), & \text{else.} \end{cases}$$

[0105] The damping values in this IIR smoothing are chosen to be

$$g_{hr,max} = 1$$

$$g_{hr,min} = 0.1.$$

[0106] For the ratio of the estimated signal power $\overline{x(n)}$ of the received acoustic signal and the high frequency power

$\overline{x_{high}(n)}$, a threshold of

5

$$K_{hlr} = 15$$

has been used. As in the case of the IIR smoothing filters of first order mentioned above, the smoothing constant β_{hlr} has been chosen from the interval

10

$$0 < \beta_{hlr} \leq 1.$$

[0107] In particular, the constant may take the value

15

$$\beta_{hlr} = 0.0005.$$

20

[0108] In addition to weighting the upper extension signal, also the signal in the frequency band of the received acoustic signal may be weighted or modified. This will yield a more harmonic resulting signal with extended bandwidth. Such a modification or weighting of the received acoustic signal $x(n)$ may be achieved via an FIR filter with two time dependent coefficients according to

25

$$y_{tel}(n) = h_0(n)x(n) + h_1(n)x(n-1)$$

30

[0109] The filter coefficients depend on each other according to

35

$$h_0(n) = \frac{1}{1 - ag_h(n)}$$

40

$$h_1(n) = 1 - h_0(n).$$

[0110] In this way, a weighted sum of the received acoustic signal at time n and at time $n-1$ is performed in block 108. The weights for this processing, as in the case of the factors for the other signal parts, are determined in block 107.

45

[0111] The filter 108 may show a small high-pass characteristic which can be activated and deactivated via the parameter α and the time dependent factor $g_h(n)$. The parameter α may be chosen from the interval

$$0.2 < \alpha < 0.8$$

50

[0112] Small values for α result in only a small increase in the upper frequencies whereas large values result in a large increase. The factor $g_h(n)$ may be chosen to be

55

$$g_h(n) = g_{snr}(n)g_{noise}(n).$$

[0113] In this way, the filter 108 is activated only during speech activity and only for received acoustic signals with low noise level. Examples for such a filter characteristic with a parameter of $a = 0.3$ at different factors $g_n(n)$ are shown in Figure 6.

[0114] The lower extensions signal $y_{low}(n)$ may be weighted as well using a time dependent factor $g_{low}(n)$ as:

$$g_{low}(n) = g_{low,fix} g_{snr}(n);$$

wherein the constant factor $g_{low,fix}$ is chosen between

$$0 \leq g_{low,fix} \leq 10.$$

[0115] As an example, the factor $g_{low,fix}$ may take a value of 2.

[0116] The output signal showing an extended bandwidth resulting from the above processing of the received acoustic signal is a weighted sum of the modified input signal (modified received acoustic signal) $y_{tel}(n)$, of the lower extension signal $y_{low}(n)$ and the upper extension signal $y_{high}(n)$;

$$y(n) = y_{tel}(n) + g_{low}(n)y_{low}(n) + g_{high}(n)y_{high}(n).$$

[0117] The overall factor for the upper extension signal may be chosen to be

$$g_{high}(n) = g_{high,fix} g_{snr}^2(n) g_{noise}(n) g_{hfr}(n).$$

[0118] The constant factor $g_{high,fix}$ may also be chosen from the interval

$$0 \leq g_{high,fix} \leq 10.$$

[0119] As an example, $g_{high,fix} = 4$.

[0120] Figure 7 illustrates an example for the method described above. In the upper part of this figure, a time versus frequency analysis of a signal $x(n)$ received via a GSM telephone is shown. As one can see, below approximately 200 Hz and above approximately 3700 Hz, no frequency components are present.

[0121] Upon performing the above described method providing an upper and a lower extension signal, the missing frequency components are re-constructed. A time versus frequency analysis of the output signal $y(n)$ is shown in the lower part of Figure 7.

[0122] It is to be understood that the different parts and components of the method and apparatus described above can also be implemented independent of each other and be combined in different form. Furthermore, the above described embodiments are to be construed as exemplary embodiments only.

Claims

1. Method for providing an acoustic signal with extended bandwidth, comprising providing an upper extension signal for extending a received acoustic signal at upper frequencies, wherein providing the upper extension signal comprises shifting the received acoustic signal at least above a predetermined lower frequency value and/or below a predetermined upper frequency value by a predetermined shifting frequency value to obtain a shifted signal.
2. Method according to claim 1, wherein the step of shifting is preceded by high-pass filtering the received acoustic signal.

3. Method according to claim 1 or 2, wherein the step of shifting is followed by high-pass filtering the shifted signal to obtain a filtered shifted signal.
- 5 4. Method according to claim 3, wherein the cutoff frequency of a high-pass filter for high-pass filtering the shifted signal corresponds to the cutoff frequency of a high-pass filter filtering the received acoustic signal plus the predetermined shifting frequency value.
- 10 5. Method according to one of the claims 2 - 4, wherein high-pass filtering the received acoustic signal and/or high-pass filtering the shifted signal is performed using a recursive filter, in particular, a Chebyshev and/or a Butterworth filter.
- 15 6. Method according to one of the preceding claims, wherein the step of shifting comprises performing a cosine modulation of the received acoustic signal.
- 20 7. Method according to one of the preceding claims, further comprising combining the received acoustic signal and the upper extension signal by providing a weighted sum of the received acoustic signal and the upper extension signal.
- 25 8. Method according to claim 7, wherein the weights of the weighted sum are time dependent.
- 30 9. Method according to claim 7 or 8, wherein the upper extension signal is weighted with a first factor, wherein the first factor is a function of an estimated signal-to-noise ratio of the received acoustic signal.
- 35 10. Method according to claim 9, wherein the first factor is a monotonically increasing function of the estimated signal-to-noise ratio of the received acoustic signal.
- 40 11. Method according to one of the claims 7 - 10, wherein the upper extension signal is weighted with a second factor, wherein the second factor is a function of an estimated noise level in the upper extension signal.
- 45 12. Method according to claim 11, wherein the second factor is a monotonically decreasing function of the estimated noise level in the upper extension signal.
- 50 13. Method according to one of the claims 7 - 12, wherein the estimated signal-to-noise ratio and/or the estimated noise level are estimated based on the respective short time signal power.
- 55 14. Method according to one of the claims 7 - 13, wherein the upper extension signal is weighted with a third factor, wherein the third factor is controlled based on the ratio of an estimated signal level of the received acoustic signal to an estimated signal level of the upper extension signal.
15. Method according to claim 14, wherein the third factor is a monotonically increasing function of the ratio of the estimated signal level of the received acoustic signal to the estimated signal level of the upper extension signal.
16. Method according to one of the claims 7 - 15, wherein the received acoustic signal is weighted by providing a weighted sum of the received acoustic signal at a current time and at the current time minus one time step.
17. Method according to claim 16, wherein the weights of the weighted sum of the received acoustic signal at the current time and at the current time minus one time step are functions of an estimated signal-to-noise ratio of the received acoustic signal and/or of an estimated noise level in the upper extension signal.
18. Method according to one of the preceding claims, further comprising providing a lower extension signal for extending the received signal at lower frequencies.
19. Method according to claim 18, wherein providing a lower extension signal comprises applying a nonlinear, in particular, a quadratic, characteristic on the received acoustic signal.
20. Method according to claim 19, wherein the nonlinear characteristic is time dependent.
21. Method according to claim 19 or 20, wherein applying a nonlinear characteristic is followed by band-pass filtering the resulting signal.

22. Method according to one of the claims 18 - 21, further comprising combining the received acoustic signal and the lower extension signal by providing a weighted sum of the received acoustic signal and the lower extension signal.

5 23. Method according to claim 22, wherein the lower extension signal is weighted with a fourth factor, wherein the fourth factor is a function of an estimated signal-to-noise ratio of the received acoustic signal.

24. Computer program product comprising one or more computer readable media having computer-executable instructions for performing the steps of the method of one of the preceding claims when run on a computer.

10 25. Apparatus for providing an acoustic signal with extended bandwidth, comprising means for providing an upper extension signal for extending a received acoustic signal at upper frequencies, wherein the means for providing the upper extension signal is configured to shift the received acoustic signal at least above a predetermined lower frequency value and/or below a predetermined upper frequency value by a predetermined shifting frequency value to obtain a shifted signal.

15

20

25

30

35

40

45

50

55

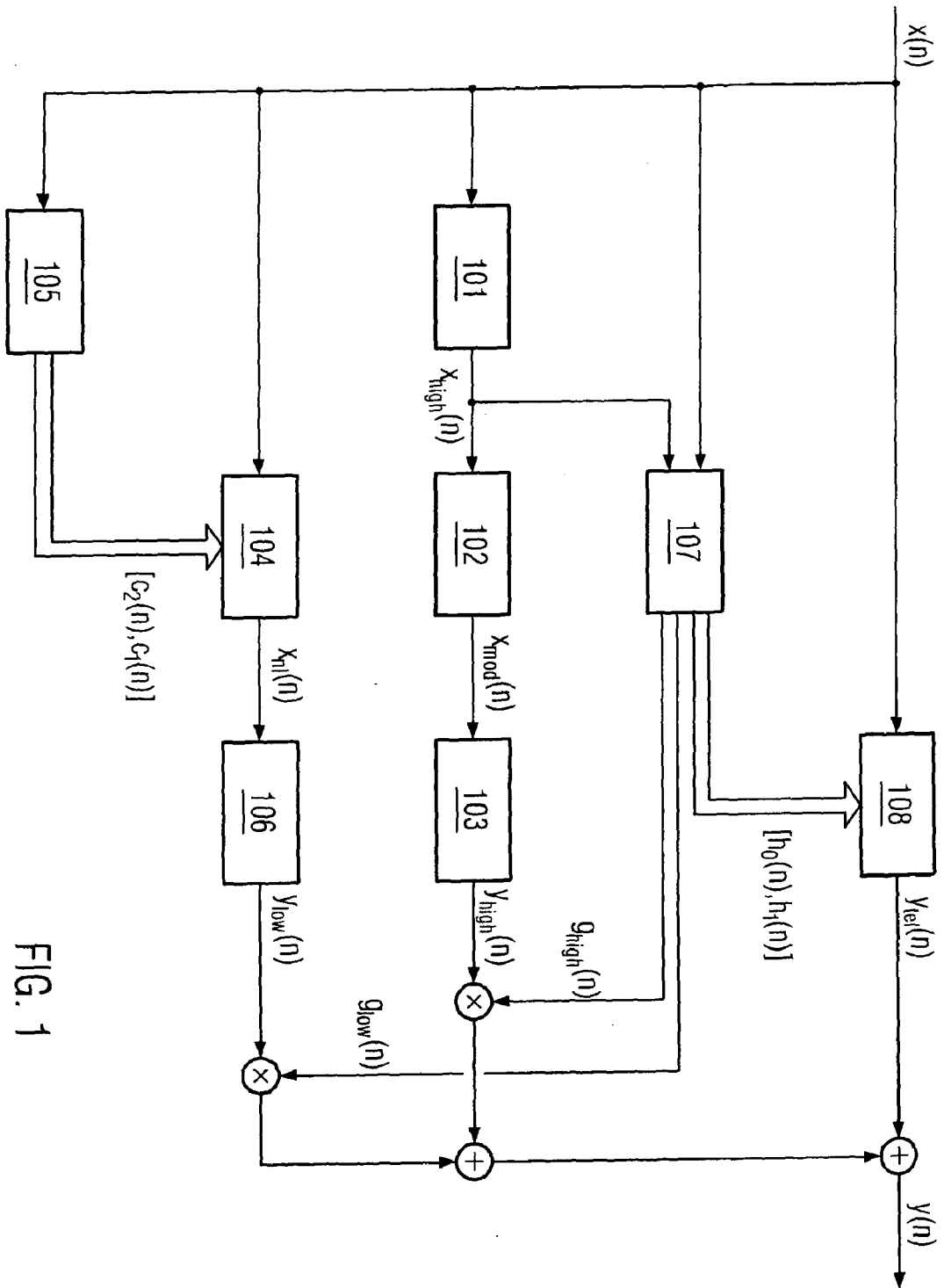

FIG. 1

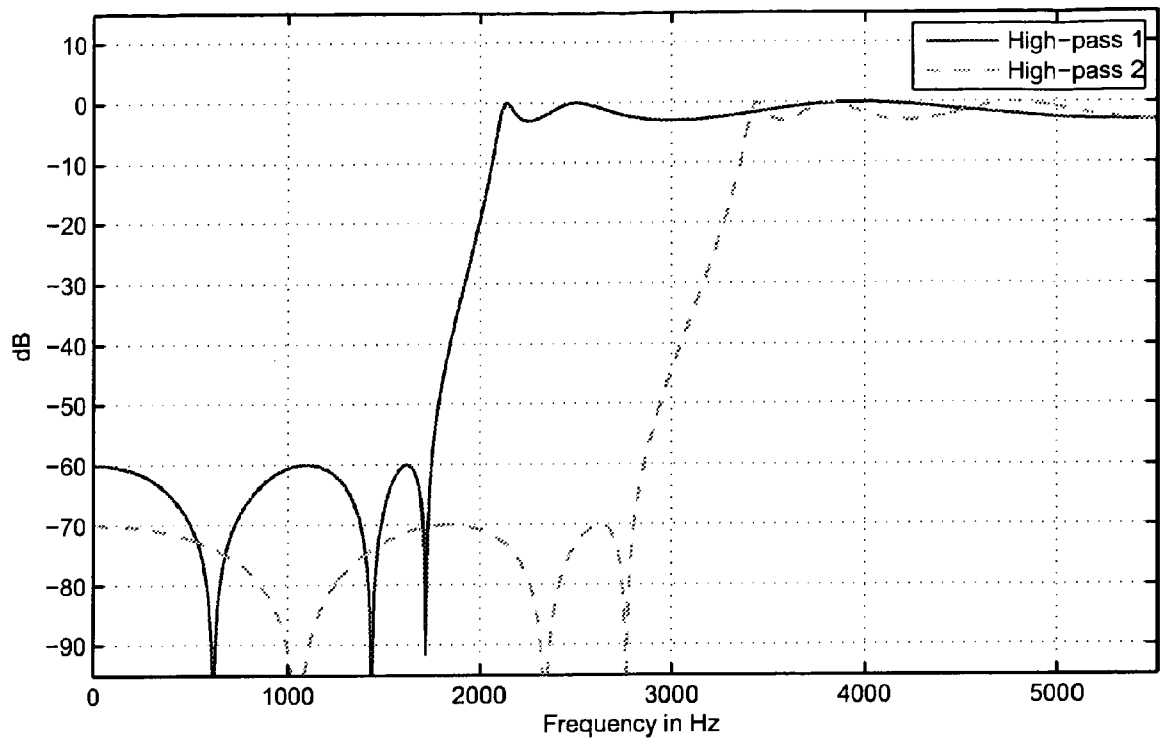

Fig. 2

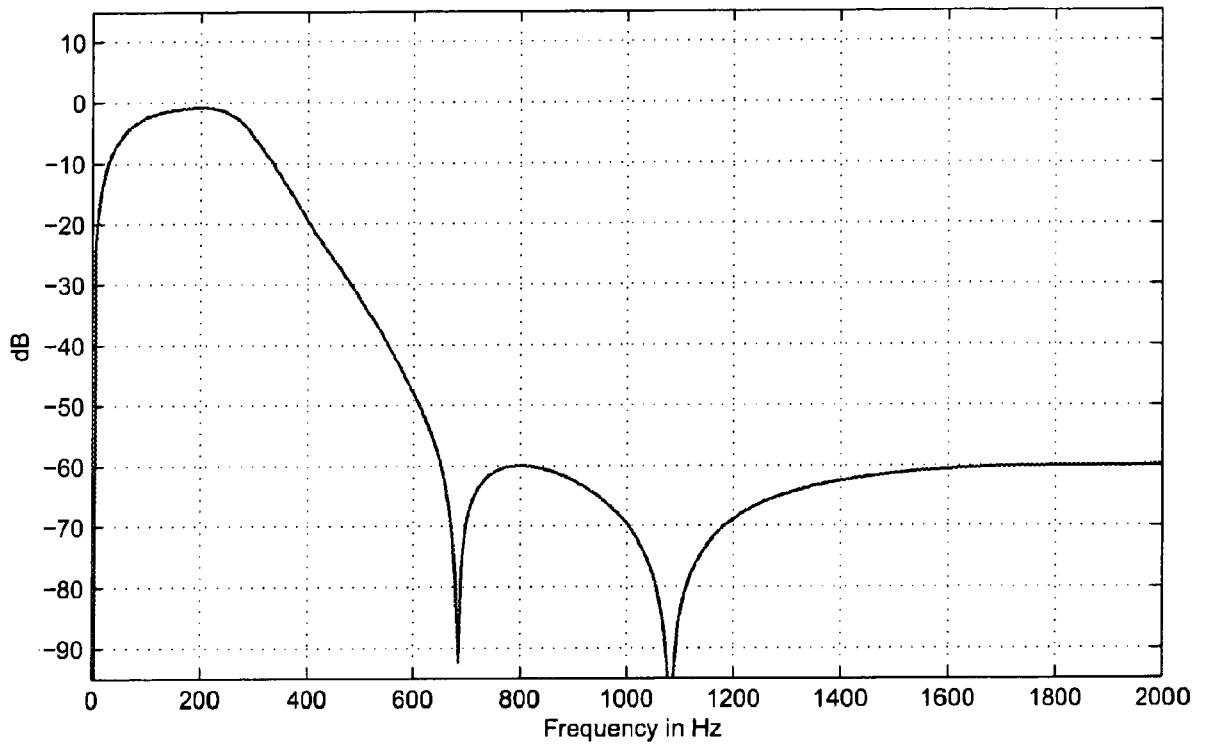

Fig. 3

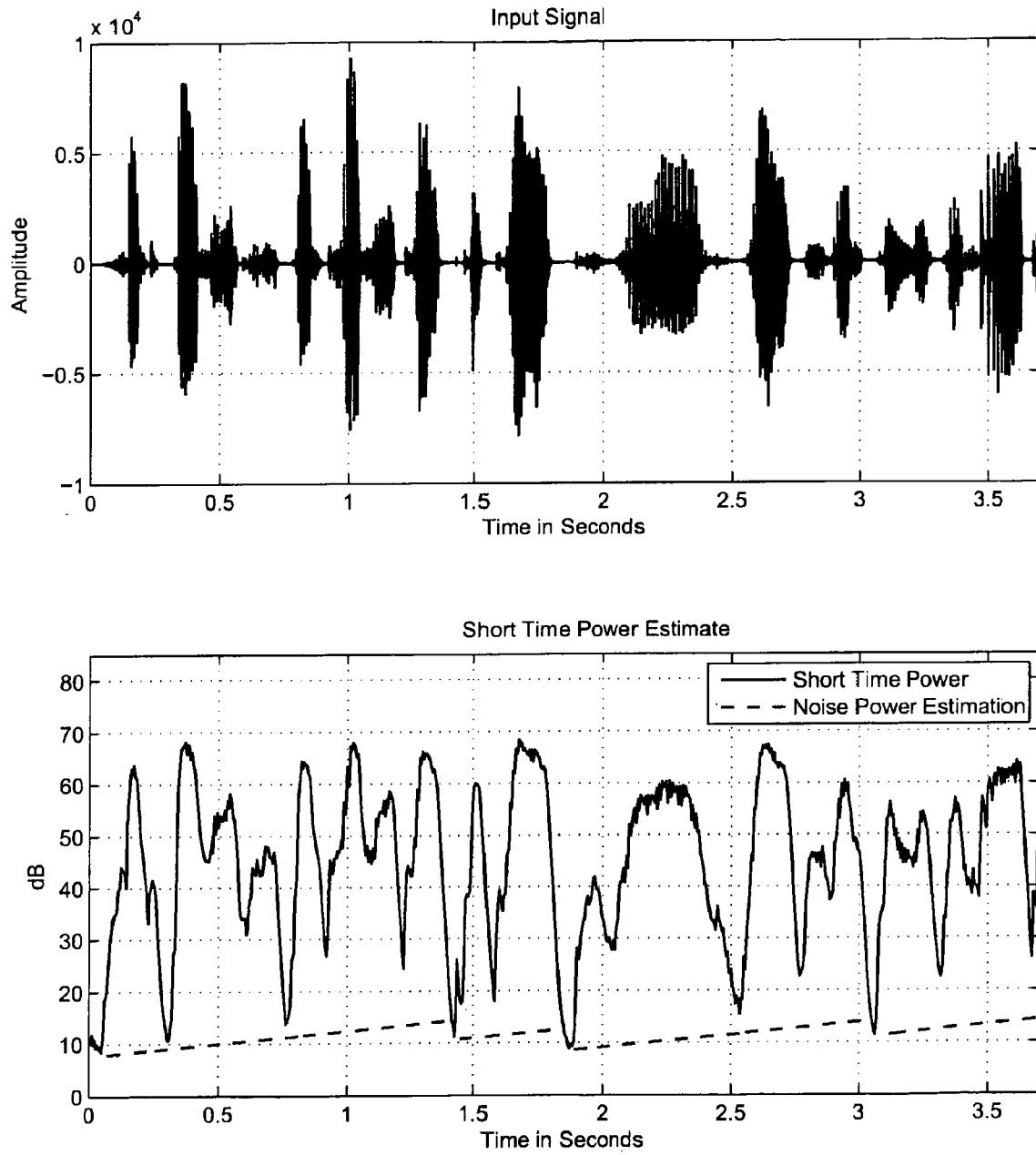

Fig. 4

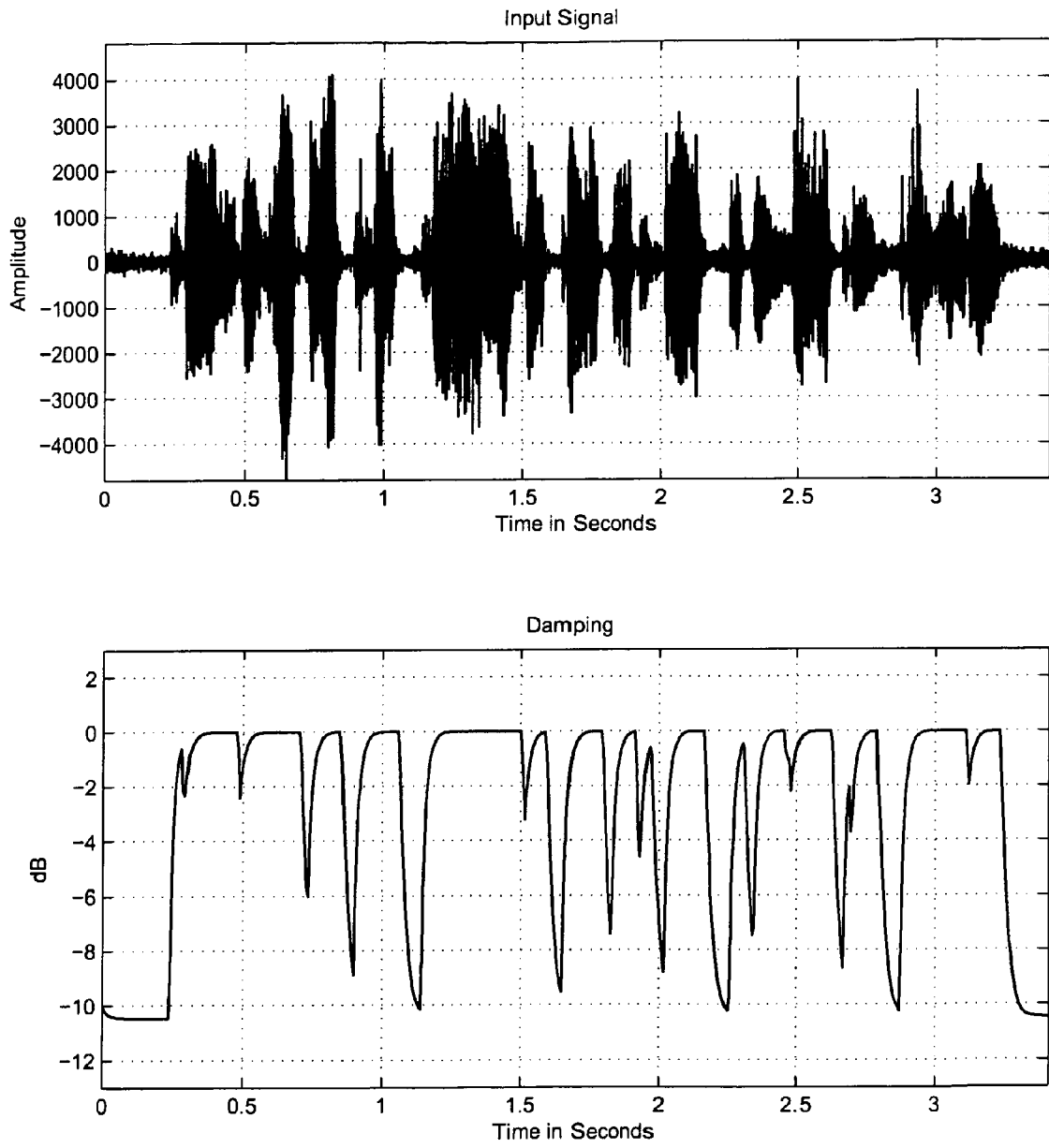

Fig. 5

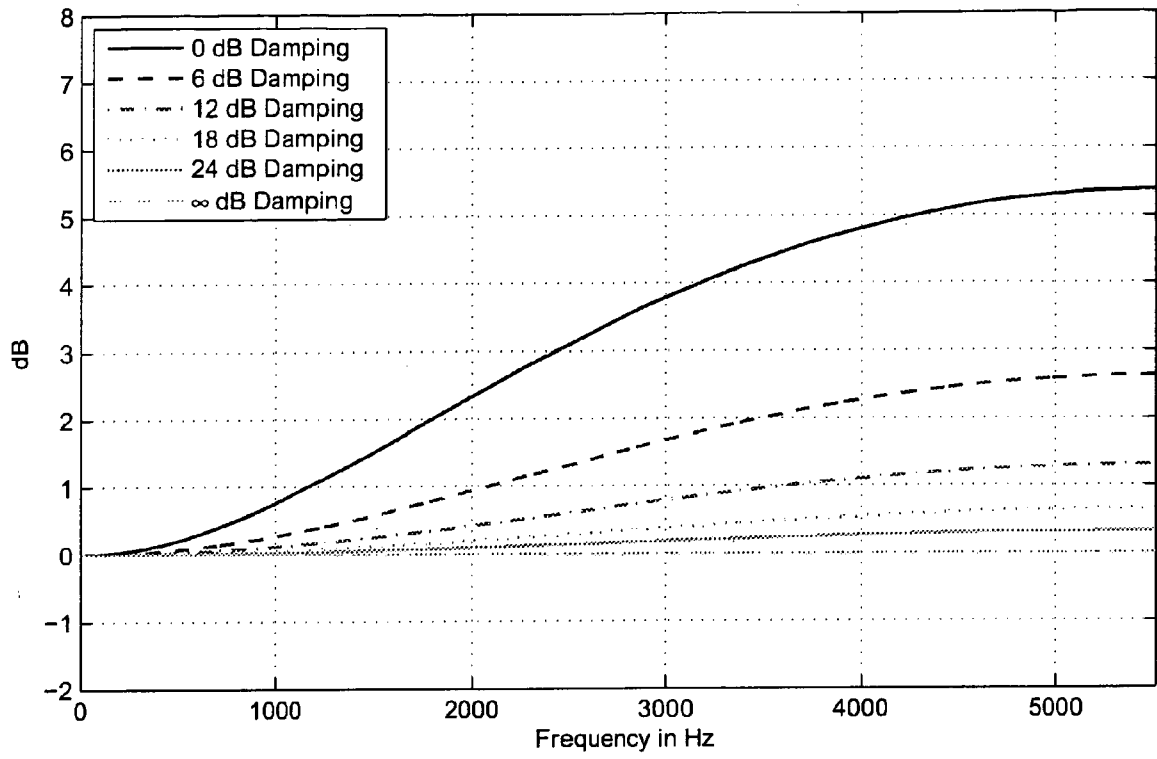

Fig. 6

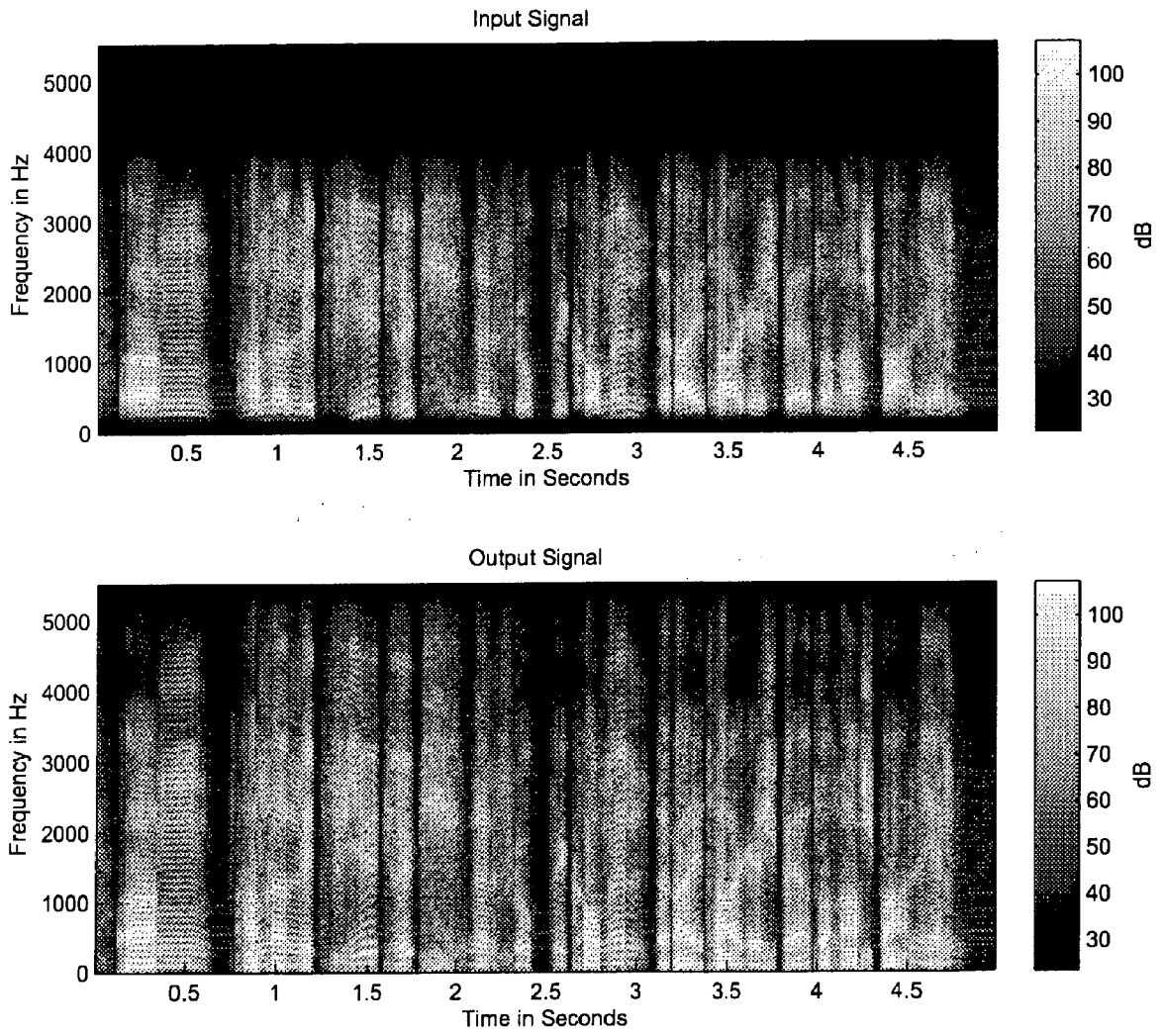

Fig. 7

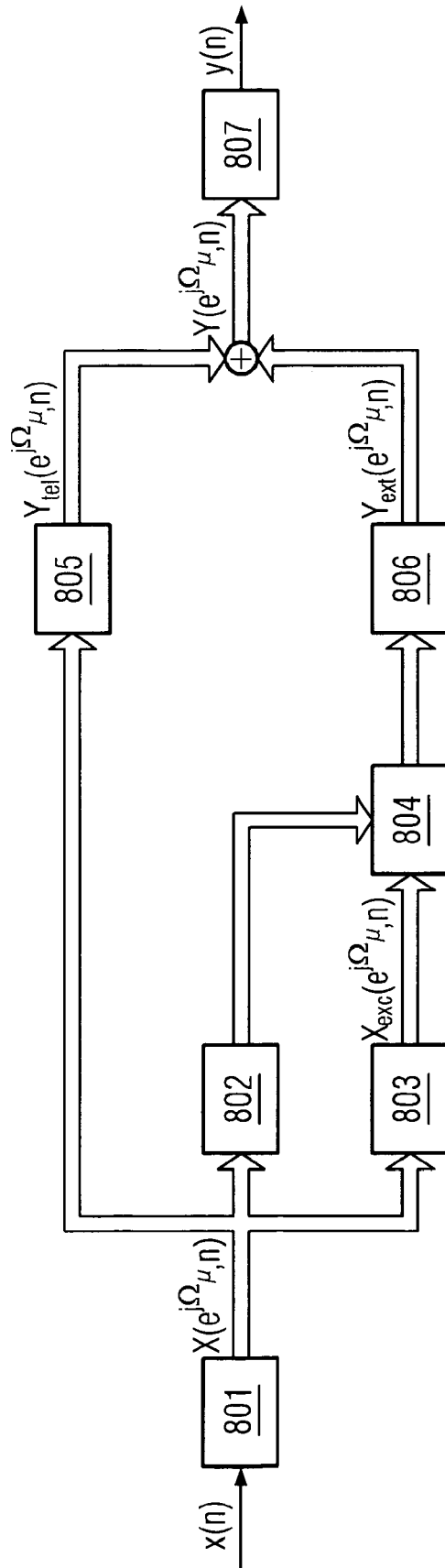

FIG. 8



DOCUMENTS CONSIDERED TO BE RELEVANT			
Category	Citation of document with indication, where appropriate, of relevant passages	Relevant to claim	CLASSIFICATION OF THE APPLICATION (IPC)
X	US 2003/187663 A1 (TRUMAN MICHAEL MEAD [US] ET AL) 2 October 2003 (2003-10-02)	1,24,25	INV. G10L21/02
Y	* column 10, paragraph 62 - column 11, paragraph 67 *	18-21	
X	EP 1 367 566 A2 (CODING TECHNOLOGIES SWEDEN AB [SE] CODING TECHNOLOGIES AB [SE]) 3 December 2003 (2003-12-03)	1,24,25	
Y	* page 3, paragraph 12 - page 4, paragraph 14 * * page 9, paragraph 40 - page 15, paragraph 63 *	18-21	
Y	ISER B ET AL: "BANDWIDTH EXTENSION OF TELEPHONY SPEECH" EURASIP NEWS LETTER, vol. 16, no. 2, June 2005 (2005-06), pages 2-24, XP002372006 ISSN: 1687-1421	18-21	
A	YASUKAWA H ED - EUROPEAN SPEECH COMMUNICATION ASSOCIATION (ESCA): "ENHANCEMENT OF TELEPHONE SPEECH QUALITY BY SIMPLE SPECTRUM EXTRAPOLATION METHOD" 4TH EUROPEAN CONFERENCE ON SPEECH COMMUNICATION AND TECHNOLOGY. EUROSPEECH '95. MADRID, SPAIN, SEPT. 18 - 21, 1995, EUROPEAN CONFERENCE ON SPEECH COMMUNICATION AND TECHNOLOGY. (EUROSPEECH), MADRID : GRAFICAS BRENDS, ES, vol. VOL. 2 CONF. 4, 18 September 1995 (1995-09-18), pages 1545-1548, XP000854997 MAdrid, Spain * page 1546, left-hand column, line 2 - line 19; figure 2 *	1-24	TECHNICAL FIELDS SEARCHED (IPC) G10L
The present search report has been drawn up for all claims			
Place of search The Hague		Date of completion of the search 31 May 2007	Examiner Burchett, Stefanie
CATEGORY OF CITED DOCUMENTS X : particularly relevant if taken alone Y : particularly relevant if combined with another document of the same category A : technological background O : non-written disclosure P : intermediate document		T : theory or principle underlying the invention E : earlier patent document, but published on, or after the filing date D : document cited in the application L : document cited for other reasons & : member of the same patent family, corresponding document	

EPO FORM 1503 (03.02) (F04C01)

**ANNEX TO THE EUROPEAN SEARCH REPORT
ON EUROPEAN PATENT APPLICATION NO.**

EP 07 00 1062

This annex lists the patent family members relating to the patent documents cited in the above-mentioned European search report. The members are as contained in the European Patent Office EDP file on
The European Patent Office is in no way liable for these particulars which are merely given for the purpose of information.

31-05-2007

Patent document cited in search report	Publication date	Patent family member(s)	Publication date
US 2003187663 A1	02-10-2003	AU 2003239126 A1	13-10-2003
		CA 2475460 A1	09-10-2003
		CN 1639770 A	13-07-2005
		EP 1488414 A1	22-12-2004
		JP 2005521907 T	21-07-2005
		MX PA04009408 A	25-01-2005
		WO 03083834 A1	09-10-2003
-----	-----	-----	-----
EP 1367566 A2	03-12-2003	NONE	
-----	-----	-----	-----

REFERENCES CITED IN THE DESCRIPTION

This list of references cited by the applicant is for the reader's convenience only. It does not form part of the European patent document. Even though great care has been taken in compiling the references, errors or omissions cannot be excluded and the EPO disclaims all liability in this regard.

Non-patent literature cited in the description

- **P. JAX.** Enhancement of Bandwidth Limited Speech Signals: Algorithms and Theoretical Bounds. Aachen, 2002 [0006]
- **E. LARSEN ; R.M. AARTS.** Audio Bandwidth Extension. Wiley, 2004 [0006]
- **J. EPPS ; W.H. HOLMES.** A New Technique for Wideband Enhancement of Coded Narrowband Speech. *IEEE Workshop on Speech Coding, Conference Proceedings*, June 1999, 174-176 [0008]
- **J.-M. VALIN ; R. LEFEBVRE.** Bandwidth Extension of Narrowband Speech for Low Bit-Rate Wideband Coding. *IEEE Workshop on Speech Coding, Conference Proceedings*, September 2000, 130-132 [0008]
- **B. ISER ; G. SCHMIDT.** Bandwidth Extension of Telephony Speech. *EURASIP Newsletter*, June 2005, vol. 16 (2), 2-24 [0009]
- **U. KORNAGEL.** Spectral Widening of the Excitation Signal for Telephone-Band Speech Enhancement. *IWAENC '01, Conference Proceedings*, September 2001, 215-218 [0010]
- Transmission Planning Aspects of the Speech Service in the GSM Public Land Mobile Network (PLMS) System. *ETS 300 903 (GSM 03.50)*, 1999 [0015]
- General Characteristics of International Telephone Connections and International Telephone Circuits - Acoustic Echo Controllers. *ITU-T Recommendation G. 167*, 1993 [0015]