



(12) **EUROPEAN PATENT APPLICATION**

(43) Date of publication:
20.01.2010 Bulletin 2010/03

(51) Int Cl.:
H04R 3/00 (2006.01)

(21) Application number: **08012866.3**

(22) Date of filing: **16.07.2008**

(84) Designated Contracting States:
AT BE BG CH CY CZ DE DK EE ES FI FR GB GR HR HU IE IS IT LI LT LU LV MC MT NL NO PL PT RO SE SI SK TR
 Designated Extension States:
AL BA MK RS

- **Buck, Markus**
88400 Biberach (DE)
- **Schmidt, Gerhard**
89081 Ulm (DE)

(71) Applicant: **Harman Becker Automotive Systems GmbH**
76307 Karlsbad (DE)

(74) Representative: **Grünecker, Kinkeldey, Stockmair & Schwanhäusser**
Anwaltssozietät
Leopoldstrasse 4
80802 München (DE)

(72) Inventors:
 • **Wolff, Tobias**
89231 Neu-Ulm (DE)

(54) **Beamforming pre-processing for speaker localization**

(57) The present invention relates a method for signal processing comprising the steps of obtaining a first plurality of microphone signals by a first microphone array; obtaining a second plurality of microphone signals by a second microphone array different from the first microphone array; beamforming the first plurality of microphone signals by a first beamformer comprising beam-

forming weights to obtain a first beamformed signal; and beamforming the second plurality of microphone signals by a second beamformer comprising the same beamforming weights as the first beamformer to obtain a second beamformed signal; and wherein the beamforming weights are adjusted such that the power density of echo components and/or noise components present in the first and second plurality of microphone signals is minimized.

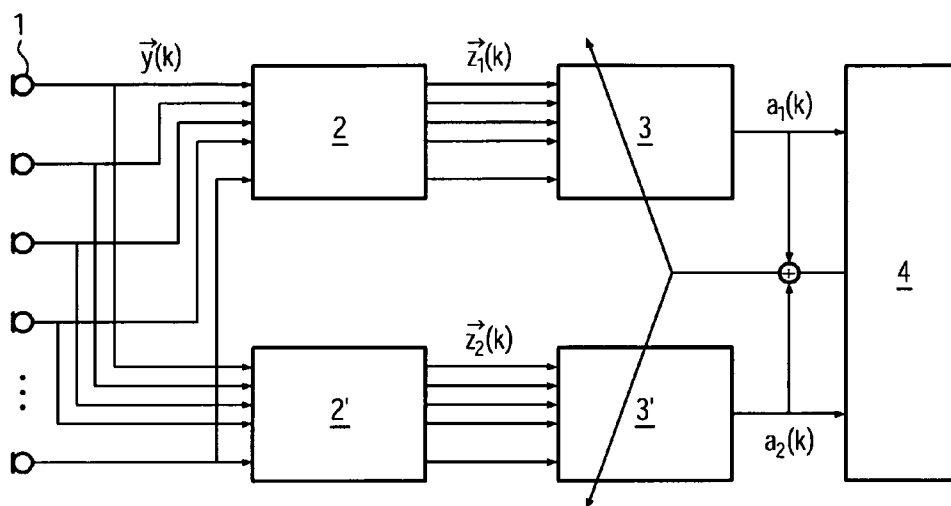

FIG. 1

Description**Field of Invention**

5 [0001] The present invention relates to the localization of speakers, in particular, speakers communicating with remote parties by means of hands-free sets or speakers using a speech control or speech recognition means comprised in some communication means. Particularly, the present invention relates to the localization of a speaker including pre-processing of microphone signals by beamforming.

10 **Background of the invention**

[0002] The localization of one or more speakers (communication parties) is of importance in the context of many different electronically mediated communication situations where multiple microphones, e.g., microphone arrays or distributed microphones are utilized. For example, the intelligibility of speech signals that represent utterances of users of handsfree sets and are transmitted to a remote party heavily depends on an accurate localization of the speaker. If accurate localization of a near end speaker fails, the transmitted speech signal exhibits a low signal-to-noise ratio (SNR) and may even be dominated by some undesired perturbation caused by some noise source located in the vicinity of the speaker or in the same room in which the speaker uses the hands-free set.

15 [0003] Audio and video conferences represent other examples in which accurate localization of the speaker(s) is mandatory for a successful communication between near and remote parties. The quality of sound captured by an audio conferencing system, i.e. the ability to pick up voices and other relevant audio signals with great clarity while eliminating irrelevant background noise (e.g. air conditioning system or localized perturbation sources) can be improved by a directionality of the voice pick up means.

20 [0004] Audio and video conferences represent other examples in which accurate localization of the speaker(s) is mandatory for a successful communication between near and remote parties. The quality of sound captured by an audio conferencing system, i.e. the ability to pick up voices and other relevant audio signals with great clarity while eliminating irrelevant background noise (e.g. air conditioning system or localized perturbation sources) can be improved by a directionality of the voice pick up means.

[0005] In the context of speech recognition and speech control the localization of a speaker is of importance in order to provide the speech recognition means with speech signals exhibiting a high signal-to-noise ratio, since otherwise the recognition results are not sufficiently reliable.

25 [0005] Acoustic localization of a speaker is usually based on the detection of transit time differences of sound waves representing the speaker's utterances by means of multiple (at least two) microphones. However, in the art methods for the localization of a speaker are error-prone in acoustic rooms that exhibit a significant reverberation and, in particular, in the context of communication systems providing audio output by some loudspeakers. In order to avoid erroneous speaker localization due to acoustic loudspeaker outputs echo compensation filtering means are usually employed in order to pre-process the microphone signals used for the speaker localization.

30 [0006] Echo compensation by filtering means allow for the reduction of echo components, in particular, due to loudspeaker outputs, by estimating echo components of the impulse response and adapting filter coefficients in order to suppress the echo components. However, echo suppression by multi-channel echo compensating filters and, particularly, the control of the adaptation of the respective filter coefficients demands for relatively powerful computer resources and results in heavy processor load. Moreover, inefficient echo compensating still results in erroneous speaker localization. Therefore, there is a need for a method for a more reliable localization of a speaker without the demand for powerful computer resources.

40

Description of the Invention

[0007] The above-mentioned problem is solved by the method for signal processing according to claim 1 that can be used as pre-processing in a procedure for the localization of a speaker (speaking person) in a room in that at least one loudspeaker and at least one microphone array are located. The claimed method for signal processing comprises the steps of

45 obtaining a first plurality of microphone signals by a first microphone array;
obtaining a second plurality of microphone signals by a second microphone array different from the first microphone array;
beamforming the first plurality of microphone signals by a first beamformer comprising beamforming weights to obtain a first beamformed signal; and
50 beamforming the second plurality of microphone signals by a second beamformer comprising the same beamforming weights as the first beamformer to obtain a second beamformed signal;
and wherein

the beamforming weights are adjusted (adapted) such that the power density of echo components and/or noise components present in the first and second plurality of microphone signals is minimized.

55 [0008] The operation of beamformers per se is well-known in the art (see, E. Hänsler and G. Schmidt, " Acoustic Echo and Noise Control: A Practical Approach", Wiley IEEE Press, New York, NY, USA, 2004). In the present invention, the first and second beamformers can be chosen from the group consisting of an adaptive filter-and-sum beamformer, a

Linearly Constrained Minimum Variance beamformer, e.g., a Minimum Variance Distortionless Response beamformer and a differential beamformer.

5 [0009] The Linearly Constrained Minimum Variance beamformer can be advantageously used to account for a distortion-free transfer in a particular direction. Moreover, it can account for so-called "derivative constraints" including constraints on derivations of the directional characteristic of the beamformer. The differential beamformer allows for the formation of hard/ highly localized spatial nullings in particular directions, e.g., in the directions of one or more loudspeakers.

10 [0010] The method can be generalized to more than two microphone arrays and more than two beamformers in a straightforward way. In this case $N > 2$ microphone arrays to obtain N pluralities of microphone signals and N beamformers are employed and the beamforming weights (filter coefficients) of the N beamformers are adjusted such that power density of echo components and/or noise components present in the N pluralities of microphone signals is minimized. The beamformers are not necessarily realized in form of separate physical units.

15 [0011] The first and second beamformers are adapted such that echo/noise present in the microphone signals is minimized and the thus enhanced beamformed microphone signals can be used for any kind of speaker localization known in the art. For instance, the beamformed signals can be input into a speaker localization means that estimates the cross power density spectrum of the beamformed signals by spatial averaging after Fast Fourier transformation of these signals. After Inverse Fourier transformation of the estimated cross power density spectrum the cross correlation function is obtained. The location of the maximum of the cross correlation function is indicative for the inclination direction of the sound detected by the microphone arrays.

20 [0012] Since the beamformers are adapted in order to reduce the echo/noise components a downstream processing for speaker localization is more reliable in the art, since perturbations that might lead to misinterpretations of the direction of a speaker with respect to the microphone arrays are significantly reduced. In particular, echo components, e.g., caused by loudspeaker outputs of loudspeakers installed in the same room as the microphone arrays are suppressed without the need for echo compensation filtering means that are conventionally employed in order to enhance the reliability of speaker localization and that are very expensive in terms of processing load.

25 [0013] According to an embodiment of the inventive method the beamforming weights (filter coefficients of the first and second beamformers) are adjusted (adapted) such that the power density of the sum of the first and the second beamformed signals (or N beamformed signals) is minimized. According to an alternative embodiment the beamforming weights are adjusted such that the sum of the power density of the first beamformed signal and the power density of the second beamformed signal (sum of the power density of N beamformed signals) is minimized. Both alternatives provide an efficient and reliable way to minimize echo/noise components that are present in the microphone signals detected by the first and second microphone arrays before beamforming.

30 [0014] Adaptation of the beamforming weights can be achieved by any method known in the art. For instance, a Normalized Least Mean Square algorithm can be used for the adaptation of the beamformers (beamforming weights). The Non-Linear Least Mean Square algorithm may particularly be employed observing the condition that the L_2 norm of the vector of the beamforming weights is greater than zero. This condition guarantees that the Non-Linear Least Mean Square algorithm does not find (and be fixed to) the trivial solution of vanishing beamforming weights.

35 [0015] Moreover, the beamforming weights of the first and second beamformer may be adjusted by a Non Linear Least Mean Square algorithm observing the condition that the power transfer function of the first and the second beamformers for a predetermined frequency range and a predetermined range of spatial angles does not fall below a predetermined limit. Thereby, it is avoided that output signals of the employed beamformers approximate zero which would result in a sharp blinding out of particular directions / inclinations of sound which possibly would undesirably affect subsequent processing of the output signals of the beamformers for speaker localization.

40 [0016] The first and the second microphone arrays can represent different sub-arrays of a third larger microphone array and the first and second plurality of microphone signals can be selected from a third plurality of microphone signals obtained by the third microphone array. In particular, the first plurality of microphone signals comprises at least one microphone signal of the second plurality of microphone signals.

45 [0017] The sub-arrays can, e.g., be chosen such that the distance between centers of the sub-arrays is maximized. Thereby, it is achieved that the output signals of the beamformer show a maximum phase difference. In particular, it shall be avoided that the centers of the selected sub-arrays overlap each other.

50 [0018] As already stated the herein disclosed method for signal processing can be used as a pre-processing step within speaker localization. Thus, it is provided a method for the localization of a speaker, wherein the method comprises the steps of the method for signal processing according to one of the above-described examples and wherein the method further comprises the determination of the speaker's direction towards and/or distance from the first and/or second microphone arrays on the basis of the first and/or second beamformed signals. Acoustic localization of a speaker can be performed on the basis of the beamformed signals by any means known in the art. It can be performed is based on the detection of transit time differences of sound waves representing the speaker's utterances.

55 [0019] The above-examples of the method for signal processing can be used before actual operation of a communi-

cation means that comprises a means for the localization of a speaker. The means for the localization of a speaker can be calibrated by adaptation of the beamforming weights of the first and second beamformers. The calibration is carried out with no wanted signal present (see detailed description below). In the subsequent operation of the communication means the beamforming weights (optimized for echo/noise reduction) are maintained without alteration and, thus, speaker localization is improved, since the first and second beamformers provide the means for the localization of a speaker with enhanced signals. Thus, it is provided a method for calibrating a means for the localization of a speaker comprised in a communication system that further comprises at least one loudspeaker and at least two microphone arrays, the method comprising the steps of

outputting a noise signal by the at least one loudspeaker;

detecting an audio signal comprising the noise signal by the first microphone array to obtain a first plurality of microphone signals and detecting the audio signal by the second microphone array to obtain a second plurality of microphone signals; beamforming the first plurality of microphone signals by a first beamformer comprising beamforming weights to obtain a first beamformed signal;

beamforming the second plurality of microphone signals by a second beamformer comprising the same beamforming weights as the first beamformer to obtain a second beamformed signal;

wherein the beamforming weights are adjusted such that the power density of echo components and/or noise components present in the first and/or second plurality of microphone signals is minimized; and storing and fixing the adjusted weights to calibrate the means for localization of a speaker.

[0020] In order to guarantee the most reliable calibration possible it may be determined whether speech of a local speaker (speaker that is present in the same room in that the first and second microphone arrays are installed) is present in the audio signal; and the steps of

beamforming the first plurality of microphone signals by a first beamformer comprising beamforming weights to obtain a first beamformed signal;

beamforming the second plurality of microphone signals by a second beamformer comprising the same beamforming weights as the first beamformer to obtain a second beamformed signal;

wherein the beamforming weights are adjusted such that the power density of echo components and/or noise components present in the first and/or second plurality of microphone signals is minimized; and storing and fixing the adjusted weights to calibrate the means for localization of a speaker;

may only be performed, if it is determined that no speech of a local speaker is present in the audio signal. If according to this example, it is determined that speech of a local speaker is present in the audio signal no adjustment (adaptation) of the beamforming weights for calibration of the means for speaker localization is performed.

[0021] It should also be noted that the adjustment of the beamforming weights in all of the above-described embodiments of the herein disclosed method for signal processing shall only be performed, if speech is actually detected in order to avoid maladjustment. Means for the detection of speech of a local speaker are well-known and may rely on signal analysis with respect to speech features as pitch, spectral envelope, phoneme extraction, etc.

[0022] The above-described methods of minimizing the power density of echo components and/or noise components present in the first and/or second plurality of microphone signals can also be used in the method for calibrating a means for the localization of a speaker comprised in a communication system.

[0023] Furthermore, the present invention provides a signal processing means, comprising

a first microphone array configured to obtain a first plurality of microphone signals;

a second microphone array different from the first microphone array and configured to obtain a second plurality of microphone signals;

a first beamformer comprising beamforming weights and configured to beamform the first plurality of microphone signals to obtain a first beamformed signal;

a second beamformer comprising the same beamforming weights as the first beam-former and configured to beamform the second plurality of microphone signals to obtain a second beamformed signal; and

a control means configured to adjust the beamforming weights such that the power density of echo components and/or noise components present in the first and/or second plurality of microphone signals is minimized.

[0024] The control means of the signal processing means may be is configured to adjust the beamforming weights by minimizing the power density of the sum of the first and the second beamformed signals or by minimizing the sum of the power density of the first beamformed signal and the power density of the second beamformed signal.

[0025] The first and second beamformers of the signal processing means can be chosen from the group consisting of an adaptive filter-and-sum beamformer, a Linearly Constrained Minimum Variance beamformer, a Minimum Variance Distortionless Response beamformer and a differential beamformer.

[0026] Furthermore, it is provided a communication system that is adapted for the localization of a speaker and comprises

the signal processing means according to one of the above examples;

at least one loudspeaker configured to output sound that is detected by the first and second microphone arrays of the

signal processing means of one of the above examples; and
 a processing means configured to determine the speaker's direction towards and/or distance from the first and/or second
 microphone arrays on the basis of the first and/or second beamformed signals.

5 [0027] The above-mentioned examples of a signal processing means provided in the present invention can advantageously be used in a variety of communication devices. In particular, it is provided a handsfree set, comprising the signal processing means according to one of the above examples or the above-mentioned communication system.

[0028] In addition, it is provided an audio or video conference system, comprising the signal processing means according to one of the above examples or the above-mentioned communication system.

10 [0029] Improved speaker localization facilitated by the herein disclosed pre-processing for minimizing the power density of perturbations, in particular, echoes caused by loudspeaker outputs, is advantageous in the context of machine-based speech recognition. Thus, it is provided a speech control means or speech recognition means comprising the signal processing means to one of the above examples or the the above-mentioned communication system.

15 [0030] Additional features and advantages of the present invention will be described with reference to the drawing. In the description, reference is made to the accompanying figure that is meant to illustrate preferred embodiments of the invention. It is understood that such embodiments do not represent the full scope of the invention.

[0031] Figure 1 illustrates an example of the signal processing of microphone signals according to the present invention.

20 [0032] In the present invention signal processing of microphone signals is performed in order to obtain enhanced signals that can subsequently be used for speaker localization. In the shown example, a number of microphones 1 is installed, e.g., in a closed room as a living room or a vehicle compartment. The microphones 1 are arranged in an aggregate microphone array and detect acoustic signals in the room and obtain microphone signals $\vec{y}(k) := (y_1(k), \dots, y_m(k), \dots, y_M(k))^T$ where the upper index T denotes the transposition operation. From these M microphone signals two sub-groups corresponding to a first and a second microphone array comprised in the aggregate microphone array are selected by selection means 2 and 2' that employ selection matrices \mathbf{P}_1 and \mathbf{P}_2 of dimension L x M

25

$$\vec{z}_1(k) = \mathbf{P}_1 \cdot \vec{y}(k)$$

30

$$\vec{z}_2(k) = \mathbf{P}_2 \cdot \vec{y}(k)$$

35 with the matrix elements

40

$$p_{j,l,m} \in \{0,1\}, \quad \sum_{m=1}^M p_{j,l,m} = 1.$$

45 [0033] As can be seen in Figure 1 some of the M microphones belong to both the first and the second selected group of microphones (microphone array), i.e. each of the microphone signals $\vec{y}(k)$ is transmitted to an output of at least either selection means 2 or 2' and some of the microphone signals are transmitted to both the output of selection means 2 and the one of selection means 2'.

[0034] When the microphones 1 are arranged in an equidistant manner the relation

50

$$p_{1,l,m} = p_{2,l,m+d}, \quad d \neq 0$$

55 holds. If, for example, an aggregate microphone array with M = 6 microphones is used and four output microphone signals are to be obtained at the outputs of the selections means 2 and 2', this can be achieved by

5

$$P_1 = \begin{pmatrix} 100000 \\ 010000 \\ 001000 \\ 000100 \end{pmatrix} \text{ and } P_2 = \begin{pmatrix} 001000 \\ 000100 \\ 000010 \\ 000001 \end{pmatrix}.$$

10 **[0035]** It is noted that processing can, in particular, be performed in the sub-band frequency regime. In this case, the selection matrices can be chosen differently for some or each of the sub-bands.

[0036] As shown in Figure 1 the output signals $\vec{z}_1(k)$ of the first selection means 2 and the output signals $\vec{z}_2(k)$ of the second selection means 2' are input in a first beamformer 3 and a second beamformer 3', respectively. Both beamformers 3 and 3' comprise the same beamforming weights (filter coefficients)

15

$$\vec{\omega}(k) = [\vec{\omega}_0^T(k), \dots, \vec{\omega}_n^T(k), \dots, \vec{\omega}_{N_{bf}-1}^T(k)]^T$$

20

with

25

$$\vec{\omega}_n(k) = [\omega_{1,n}(k), \dots, \omega_{l,n}(k), \dots, \omega_{L,n}(k)]^T,$$

30

wherein N_{bf} denotes the filter length of the beamformers 3 and 3'. By the beamforming processing output signals $a_1(k)$ and $a_2(k)$ are obtained

35

$$a_1(k) = \vec{\omega}^H(k) \cdot \vec{z}_1(k) \text{ and } a_2(k) = \vec{\omega}^H(k) \cdot \vec{z}_2(k).$$

40

[0037] Once more, it is noted that according to the present invention $\vec{z}_1(k)$ and $\vec{z}_2(k)$ are subject to the same beamforming process employing the same beamforming weights.

[0038] The audio signals detected by the microphones 1 and, thus, the microphone signals $\vec{y}(k)$, in general, comprise wanted contributions and perturbation contributions. The wanted contributions may, in particular, correspond to the utterance of a speaker in the room in that the microphones 1 are installed. The perturbation contributions may, in particular, comprise echo components caused by a loudspeaker output of one or more loudspeakers (not shown) that are installed in the same room as the microphones 1.

45

[0039] The beamforming weights are adjusted such that the perturbation contributions are minimized. This means that the signal processing according to the present invention has to be performed for audio signals that do not comprise a wanted contribution. Either the adaptation of the beamformers 3 and 3' has to be performed before the actual usage of a communication means comprising a means for speaker localization (offline) or, if the adaptation is performed during the operation of a communication means comprising a speaker localization means, i.e. on-line, the beamforming weights have to be adjusted (adapted) during speech pauses. In this case, some speech detection means and some control means have to be employed wherein the control means allows for adaptation of the beamforming weights of the beamformers 3 and 3' adjusted during speech pauses only.

50

[0040] At least two alternative methods for realizing the minimization of the perturbation components in the output signals $a_1(k)$ and $a_2(k)$ of the first and second beamformer 3, 3' are provided herein. According to the first alternative, the power density of the sum of the outputs $a_1(k)$ and $a_2(k)$ is minimized

55

$$E \{ (a_1(k) + a_2(k)) \cdot (a_1(k) + a_2(k))^* \} \rightarrow \min .$$

5 [0041] Wherein the asterisk denotes the complex conjugate. According to the second alternative, the sum of the power densities is minimized

$$10 E \{ a_1(k) \cdot a_1(k)^* + a_2(k) \cdot a_2(k)^* \} \rightarrow \min .$$

15 [0042] Adaptation of the beamforming weights can be performed by means of the Non-Linear Least Mean Square algorithm that is well-known in the art (see, E. Hänsler and G. Schmidt, " Acoustic Echo and Noise Control: A Practical Approach", Wiley IEEE Press, New York, NY, USA, 2004) and provides a robust and relatively fast means for adaptation. However, it has to be prevented that the algorithm finds the trivial solution $\vec{w}(k) = 0$. This can be achieved, for instance, by applying the condition that the L_2 norm of the vector $\vec{w}(k) = 0$ has to be positive $\|\vec{w}(k)\|^2 > 0$. This can be realized by normalizing the beamforming weights to the vector norm after each adaptation step:

$$25 \tilde{w}(k+1) = \vec{w}(k) + \mu \cdot \frac{(\bar{z}_1(k) + \bar{z}_2(k)) \cdot (a_1(k) + a_2(k))^*}{\|\bar{z}_1(k) + \bar{z}_2(k)\|^2}$$

$$30 \vec{w}(k+1) = \frac{\tilde{w}(k+1)}{\|\tilde{w}(k+1)\|} .$$

35 [0043] Furthermore, it should be guaranteed that the output signals $a_1(k)$ and $a_2(k)$ are not minimized to zero (or almost zero) thereby causing the beamformer to suppress any signal energy of the corresponding particular direction which implies that subsequent speaker localization would not receive any information from that direction. This would possibly affect the reliability of the speaker localization. Therefore, the adaptation of the beamforming weights of the beamformers 3 and 3' might be performed under the condition

$$45 \|H_\omega(f, \theta)\|^2 \geq \varepsilon ,$$

wherein H is the power transfer function of the first and second beamformer 3 and 3' depending on the frequency f and the spatial angle θ within a predetermined range and wherein ε denotes a predetermined lower limit.

50 [0044] As already mentioned the adaptation of the beamformers 3 and 3' might be performed before an actual usage of a communication means in order to calibrate a means for speaker localization comprised in the communication means. For example, a means for speaker localization of a speech recognition means may be calibrated by means of a specially designed user dialog during which the position/direction of loudspeakers relative to a microphone array can be determined. Additionally, by the user dialog the above-mentioned predetermined range of spatial angle can be fixed. According to another example, (white) noise may be output by one or more loudspeakers and the beamforming weights may be adapted as described above based on the noise output by the loudspeaker(s).

55 [0045] All previously discussed embodiments are not intended as limitations but serve as examples illustrating features and advantages of the invention. It is to be understood that some or all of the above described features can also be combined in different ways.

Claims

1. Method for signal processing comprising the steps of
 5 obtaining a first plurality of microphone signals by a first microphone array;
 obtaining a second plurality of microphone signals by a second microphone array different from the first microphone array;
 beamforming the first plurality of microphone signals by a first beamformer comprising beamforming weights to obtain a first beamformed signal; and
 10 beamforming the second plurality of microphone signals by a second beamformer comprising the same beamforming weights as the first beamformer to obtain a second beamformed signal; and
 adjusting the beamforming weights such that the power density of echo components and/or noise components present in the first and second plurality of microphone signals is minimized.
2. The method according to claim 1, wherein the beamforming weights are adjusted such that the power density of
 15 the sum of the first and the second beamformed signals is minimized.
3. The method according to claim 1, wherein the beamforming weights are adjusted such that the sum of the power density of the first beamformed signal and the power density of the second beamformed signal is minimized.
- 20 4. The method according to one of the preceding claims, wherein the beamforming weights are adjusted by a Non-Linear Least Mean Square algorithm observing the condition that the L_2 norm of the vector of the beamforming weights is greater than zero.
- 25 5. The method according to one of the preceding claims, wherein the beamforming weights are adjusted by a Non-Linear Least Mean Square algorithm observing the condition that the power transfer function of the first and the second beamformers for a predetermined frequency range and a predetermined range of spatial angles does not fall below a predetermined limit.
- 30 6. The method according to one of the preceding claims, wherein the first and the second microphone arrays are sub-arrays of a third microphone array and the first and second plurality of microphone signals are selected from a third plurality of microphone signals obtained by the third microphone array and wherein, in particular, the first plurality of microphone signals comprises at least one microphone signal of the second plurality of microphone signals.
- 35 7. Method for the localization of a speaker, comprising the steps of the method according to one of the preceding claims and further comprising determining the speaker's direction towards and/or distance from the first and/or second microphone arrays on the basis of the first and/or second beamformed signals.
- 40 8. Signal processing means, comprising
 a first microphone array configured to obtain a first plurality of microphone signals;
 a second microphone array different from the first microphone array and configured to obtain a second plurality of microphone signals;
 a first beamformer comprising beamforming weights and configured to beamform the first plurality of microphone signals to obtain a first beamformed signal;
 45 a second beamformer comprising the same beamforming weights as the first beamformer and configured to beamform the second plurality of microphone signals to obtain a second beamformed signal; and
 a control means configured to adjust the beamforming weights such that the power density of echo components and/or noise components present in the first and/or second plurality of microphone signals is minimized.
- 50 9. The signal processing means according to claim 8, wherein the control means is configured to adjust the beamforming weights by minimizing the power density of the sum of the first and the second beamformed signals or by minimizing the sum of the power density of the first beamformed signal and the power density of the second beamformed signals.
- 55 10. The signal processing means according to claim 8 or 9, wherein the first and second beamformers are chosen from the group consisting of an adaptive filter-and-sum beamformer, a Linearly Constrained Minimum Variance beamformer, in particular, a Minimum Variance Distortionless Response beamformer, and a differential beamformer.
11. Communication system adapted for the localization of a speaker; comprising
 the signal processing means according to one of the claims 8 to 10;

at least one loudspeaker configured to output sound that is detected by the first and second microphone arrays of the signal processing means of one of the claims 8 to 10; and
a processing means configured to determine the speaker's direction towards and/or distance from the first and/or second microphone arrays on the basis of the first and/or second beamformed signals.

5

12. Handsfree set, comprising the signal processing means according to one of the claims 8 to 10 or the communication system according to claim 11.

10

13. Audio or video conference system, comprising the signal processing means according to one of the claims 8 to 10 or the communication system according to claim 11.

14. A speech control means or speech recognition means comprising the signal processing means according to one of the claims 8 to 10 or the communication system according to claim 11.

15

15. Method for calibrating a means for the localization of a speaker comprised in a communication system that further comprises at least one loudspeaker and at least two microphone arrays, the method comprising the steps of outputting a noise signal by the at least one loudspeaker;

20

detecting an audio signal comprising the noise signal by the first microphone array to obtain a first plurality of microphone signals and detecting the audio signal by the second microphone array to obtain a second plurality of microphone signals;

beamforming the first plurality of microphone signals by a first beamformer comprising beamforming weights to obtain a first beamformed signal;

beamforming the second plurality of microphone signals by a second beamformer comprising the same beamforming weights as the first beamformer to obtain a second beamformed signal;

25

wherein the beamforming weights are adjusted such that the power density of echo components and/or noise components present in the first and/or second plurality of microphone signals is minimized; and storing and fixing the adjusted weights to calibrate the means for localization of a speaker.

30

35

40

45

50

55

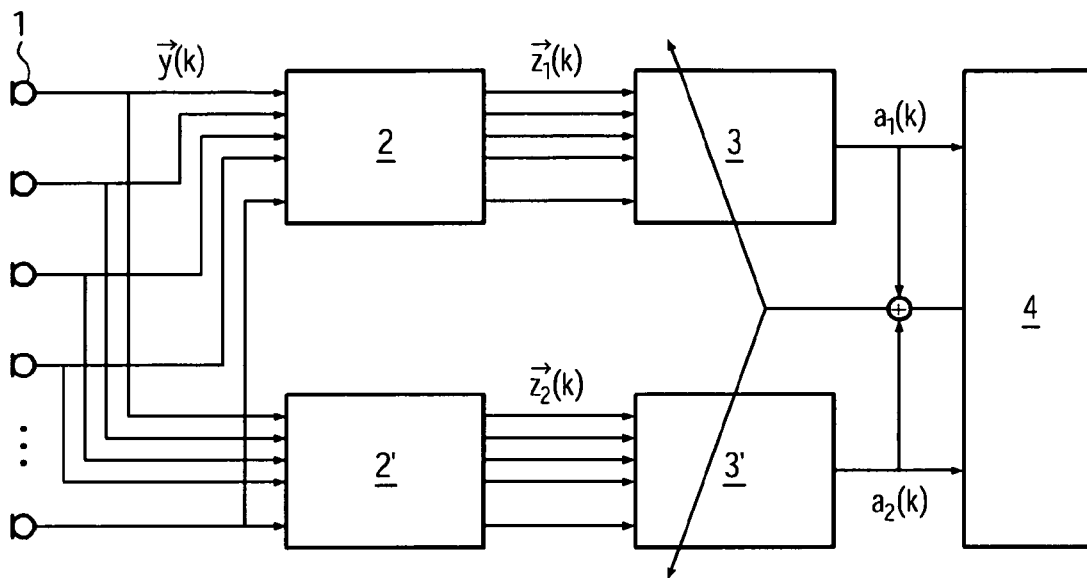

FIG. 1



EUROPEAN SEARCH REPORT

Application Number
EP 08 01 2866

DOCUMENTS CONSIDERED TO BE RELEVANT			
Category	Citation of document with indication, where appropriate, of relevant passages	Relevant to claim	CLASSIFICATION OF THE APPLICATION (IPC)
Y	EP 1 933 303 A (HARMAN BECKER AUTOMOTIVE SYS [DE]) 18 June 2008 (2008-06-18) * abstract * * paragraph [0015] - paragraph [0018] *	1-15	INV. H04R3/00
Y	CHAPMAN, D. J.: "Partial Adaptivity for the Large Array" IEEE TRANSACTIONS ON ANTENNAS AND PROPAGATION, vol. AP-24, no. 5, September 1976 (1976-09), pages 685-696, XP002501537 * page 685 * * page 686; figure 2 * * page 688 *	1-15	
A	AMAND F. ET AL.: "A fast two-channel projection algorithm for stereophonic acoustic echo cancellation" 1996 IEEE INTERNATIONAL CONFERENCE ON ACOUSTICS, SPEECH, AND SIGNAL PROCESSING CONFERENCE PROCEEDINGS, vol. 2, 7 May 1996 (1996-05-07), - 10 May 1996 (1996-05-10) pages 949-952, XP002501538 New York, NY, USA * page 949 *	3,9	TECHNICAL FIELDS SEARCHED (IPC) H04R
A	HANSLER E. AND SCHMIDT G.: "Acoustic Echo and Noise Control" 2004, JOHN WILEY & SONS, INC. , HOBOKEN, NEW JERSEY , XP002501539 ISBN: 978 0 471 45346 8 * page 77 - page 79 * * page 287 - page 292 *	1-15	
The present search report has been drawn up for all claims			
2	Place of search Munich	Date of completion of the search 29 October 2008	Examiner Guillaume, Mathieu
CATEGORY OF CITED DOCUMENTS X : particularly relevant if taken alone Y : particularly relevant if combined with another document of the same category A : technological background O : non-written disclosure P : intermediate document		T : theory or principle underlying the invention E : earlier patent document, but published on, or after the filing date D : document cited in the application L : document cited for other reasons & : member of the same patent family, corresponding document	

EPO FORM 1503 03/02 (F04/C01)



EUROPEAN SEARCH REPORT

Application Number
EP 08 01 2866

DOCUMENTS CONSIDERED TO BE RELEVANT		
Category	Citation of document with indication, where appropriate, of relevant passages	Relevant to claim
A	EP 1 727 344 A (BROADCOM CORP [US]) 29 November 2006 (2006-11-29) * abstract *	1-15
A	WO 2008/041878 A (MICRONAS NIT [RS]; SARIC ZORAN [RS]; JOVICIC SLOBODAN [RS]; KOVACEVIC) 10 April 2008 (2008-04-10) * abstract *	1-15
		TECHNICAL FIELDS SEARCHED (IPC)
The present search report has been drawn up for all claims		
Place of search	Date of completion of the search	Examiner
Munich	29 October 2008	Guillaume, Mathieu
CATEGORY OF CITED DOCUMENTS		T : theory or principle underlying the invention E : earlier patent document, but published on, or after the filing date D : document cited in the application L : document cited for other reasons & : member of the same patent family, corresponding document
X : particularly relevant if taken alone Y : particularly relevant if combined with another document of the same category A : technological background O : non-written disclosure P : intermediate document		

2
EPO FORM 1503 03.82 (P04C01)

**ANNEX TO THE EUROPEAN SEARCH REPORT
ON EUROPEAN PATENT APPLICATION NO.**

EP 08 01 2866

This annex lists the patent family members relating to the patent documents cited in the above-mentioned European search report. The members are as contained in the European Patent Office EDP file on
The European Patent Office is in no way liable for these particulars which are merely given for the purpose of information.

29-10-2008

Patent document cited in search report	Publication date	Patent family member(s)	Publication date
EP 1933303 A	18-06-2008	AT 403928 T US 2008147397 A1	15-08-2008 19-06-2008
-----	-----	-----	-----
EP 1727344 A	29-11-2006	NONE	
-----	-----	-----	-----
WO 2008041878 A	10-04-2008	NONE	
-----	-----	-----	-----

EPO FORM P0489

For more details about this annex : see Official Journal of the European Patent Office, No. 12/82

REFERENCES CITED IN THE DESCRIPTION

This list of references cited by the applicant is for the reader's convenience only. It does not form part of the European patent document. Even though great care has been taken in compiling the references, errors or omissions cannot be excluded and the EPO disclaims all liability in this regard.

Non-patent literature cited in the description

- **E. Hänsler ; G. Schmidt.** Acoustic Echo and Noise Control: A Practical Approach. Wiley IEEE Press, 2004 [0008] [0042]